

## SECTION 6C

# POWER STEERING GEAR

**CAUTION:** Disconnect the negative battery cable before removing or installing any electrical unit or when a tool or equipment could easily come in contact with exposed electrical terminals. Disconnecting this cable will help prevent personal injury and damage to the vehicle. The ignition must also be in LOCK unless otherwise noted.

## TABLE OF CONTENTS

<b>Specifications</b> .....	<b>6C-1</b>	Dust Boot .....	6C-19
General Specifications .....	6C-1	Straight Ahead Check .....	6C-20
Fastener Tightening Specifications .....	6C-2	Intermediate Shaft and Dash Seal .....	6C-21
<b>Special Tools</b> .....	<b>6C-2</b>	Hydraulic Cylinder Lines .....	6C-25
Special Tools Table .....	6C-2	Speed Sensitive Power Steering Control Module .....	6C-26
<b>Diagnosis</b> .....	<b>6C-3</b>	Speed Sensitive Power Steering Control Module Bracket .....	6C-27
Power Rack and Pinion Steering Gear .....	6C-3	Unit Repair .....	6C-29
Power Rack and Pinion Steering Gear Bench Testing .....	6C-5	Rack and Pinion .....	6C-29
Speed Sensitive Power Steering System .....	6C-6	Stub Shaft Seals and Upper and Lower Bearing .....	6C-34
Speed Sensitive Power Steering System Operating With Full Assist At All Times .....	6C-7	Rack Bearing .....	6C-38
Speed Sensitive Power Steering System Operating With Decreased Assist At All Times .....	6C-9	Rack Bearing Preload Adjustment .....	6C-40
<b>Maintenance and Repair</b> .....	<b>6C-10</b>	Valve and Pinion .....	6C-40
On-Vehicle Service .....	6C-10	<b>General Description and System</b>	
Rack and Pinion Assembly .....	6C-10	<b>Operation</b> .....	<b>6C-44</b>
Outer Tie Rod .....	6C-15	Power Rack and Pinion .....	6C-44
Inner Tie Rod .....	6C-17	Speed Sensitive Power Steering System .....	6C-44

## SPECIFICATIONS

### GENERAL SPECIFICATIONS

Application	Description
Capacity	1.0 Liter (1.06 qt)
Lubricant	Power Steering Fluid DEXRON <sup>®</sup> II or III

## FASTENER TIGHTENING SPECIFICATIONS

Application	N•m	Lb•Ft	Lb•In
Adjuster Plug	12	-	106
Adjuster Plug Locknut	75	56	-
Control Module Bracket Bolts	7	-	62
Dash Seal Retaining Ring Nuts	7	-	62
Hydraulic Cylinder Line Fittings - Cylinder End	27	20	-
Hydraulic Cylinder Line Fittings - Valve End	18	13	-
Inner Tie Rod	100	74	-
Intermediate Shaft Pinch Bolts	25	18	-
Outer Tie Rod Adjusting Nut	64	47	-
Outer Tie Rod Nuts	50	37	-
Pinion Locknut	30	22	-
Pinion Preload	1	-	9
Steering Gear Inlet and Outlet Pipe Fittings	28	21	-
Steering Gear Mounting Bracket Nuts and Bolts	60	44	-
Transaxle Center Bracket to Engine Bolt	90	66	-

## SPECIAL TOOLS

### SPECIAL TOOLS TABLE

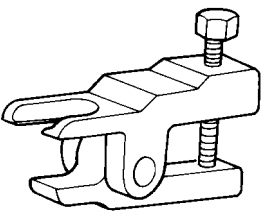
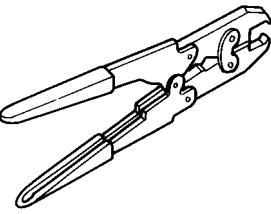
 <p>A106C034</p>	<p><b>KM-507-B Ball Joint Remover</b></p>
 <p>A104A008</p>	<p><b>KM-J-22610 Installer</b></p>

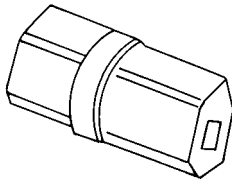
 <p>C105C001</p>	<p><b>J-42459 Rack Guide Spring Cap Wrench</b></p>
--	--

# DIAGNOSIS

## POWER RACK AND PINION STEERING GEAR

### Hissing Noise

Checks	Action
Check the intermediate shaft joints for looseness.	Tighten the intermediate shaft joints.
Check the power steering hose for contact with other components.	Be sure the power steering hose is correctly fitted into the hose clips.

### Rattling Noise in Steering Gear

Checks	Action
Check the power steering hose for contact with the body.	Be sure the power steering hose is correctly fitted into the hose clips.
Check the steering gear for insufficient lubrication.	Lubricate the steering gear.
Check the steering gear mounting for improper installation.	Tighten the steering gear mounting bracket nuts and bolts.
Check the outer tie rods for improper installation.	Tighten the outer tie rod joints. Replace the outer tie rods.

### Poor Return of Steering Wheel to Center

Checks	Action
Check the steering wheel for contact with the turn signal housing.	Adjust the turn signal housing.
Check the intermediate shaft joints for binding or looseness.	Replace the intermediate shaft.
Check the power steering pump flow control valve for sticking and improper alignment.	Replace the power steering pump.
Check the wheel alignment.	Align the wheels.
Check the wheel bearings for wear or damage.	Replace the wheel bearings.
Check the intermediate shaft joints for improper installation.	Adjust the intermediate shaft between the steering gear and the steering column. Replace the intermediate shaft.
Check the outer tie rods and the ball joints for binding or looseness.	Tighten the tie rods and the ball joints. Replace the tie rods and the ball joints.
Check the steering gear adjustments.	Perform a straightahead check.
Check the steering column shaft seal for rubbing on the shaft.	Replace the dash seal.
Check the steering shaft bearings for binding.	Replace the stub shaft bearings.

### Momentary Increase in Effort When Turning the Wheel Quickly

Checks	Action
Check the power steering pump for internal leaks.	Replace the power steering pump.
Check the hoses for damage or restricted flow.	Replace the power steering hoses and/or pipes.
Check the power steering fluid level.	Fill the power steering fluid reservoir.
Check the power steering pump flow control valve for sticking and improper operation.	Replace the power steering pump.

**Steering Surges or Jerks When Turning with Engine Running**

<b>Checks</b>	<b>Action</b>
Check the power steering pump for insufficient pressure.	Replace the power steering pump.
Check the power steering pump flow control valve for sticking and improper operation.	Replace the power steering pump.
Check the power steering pump serpentine belt for slippage.	Tighten the power steering serpentine belt.
Check for air contamination in the power steering system.	Bleed the power steering system.

**Steering Vibrates During Low Speed or Static Steering**

<b>Checks</b>	<b>Action</b>
Check for air contamination in the power steering system.	Bleed the power steering system.
Check the power steering pump serpentine belt for looseness.	Tighten the power steering serpentine belt.

**Excessive Wheel Kickback or Loose Steering**

<b>Checks</b>	<b>Action</b>
Check for air contamination in the power steering system.	Bleed the power steering system.
Check the wheel bearings for wear or damage.	Replace the wheel bearings.
Check the steering gear mounting for improper installation.	Tighten the steering gear mounting bracket nuts and bolts.
Check the intermediate shaft joints for improper installation.	Adjust the intermediate shaft between the steering gear and the steering column. Replace the intermediate shaft.
Check the outer tie rods and ball joints for looseness.	Tighten the tie rods and the ball joints. Replace the tie rods and the ball joints.

**Hard Steering or Lack of Assist (Especially During Parking)**

<b>Checks</b>	<b>Action</b>
Check the intermediate shaft joints for improper installation.	Adjust the intermediate shaft between the steering gear and the steering column. Replace the coupling flange.
Check the power steering pump flow control valve for sticking and improper installation.	Replace the power steering pump.
Check the power steering pump for insufficient pressure.	Replace the power steering pump.
Check the power steering pump for internal leaks.	Replace the power steering pump.
Check for a loose or a worn intermediate shaft.	Tighten the intermediate shaft. Replace the intermediate shaft as needed.
Check the power steering pump serpentine belt tension.	Tighten the power steering serpentine belt.

## POWER RACK AND PINION STEERING GEAR BENCH TESTING

### Removal, Setup and Testing Procedure

**Notice:** Pressure checks or pressure and flow checks may also be conducted using this set up.

1. Disconnect and remove the power steering gear. Refer to „Rack and Pinion Assembly” in this section.
2. Place the power steering gear on a bench next to the vehicle.
3. Disconnect the pressure line at the point where the hose connects to the pipe. Extend this line in order to reach the power steering gear on the bench.
4. Disconnect the return line from the the power steering fluid reservoir. Extend this line in order to reach the power steering gear on the bench.
5. Connect the power steering pipes to the power steering gear.
6. Start the engine and allow it to idle for 10 seconds.

7. Check the power steering fluid level. Refer to *Section 6A, Power Steering System*.
8. Start the engine and turn the rack and pinion stub shaft to a full turn in each direction. Hold the shaft against each stop for 5 seconds.
9. Inspect for possible leak points. Refer to *Section 6A, Power Steering System*.

### Installation Procedure

1. Stop the engine.
2. Disconnect the power steering pipes from the power steering gear.
3. Remove the extensions and reconnect the pressure and return lines.
4. Install and connect the power steering gear. Refer to „Rack and Pinion Assembly” in this section.
5. Start the engine and allow if to idle for 10 seconds.
6. Check the power steering fluid level. Refer to *Section 6A, Power Steering System*.

### SPEED SENSITIVE POWER STEERING SYSTEM

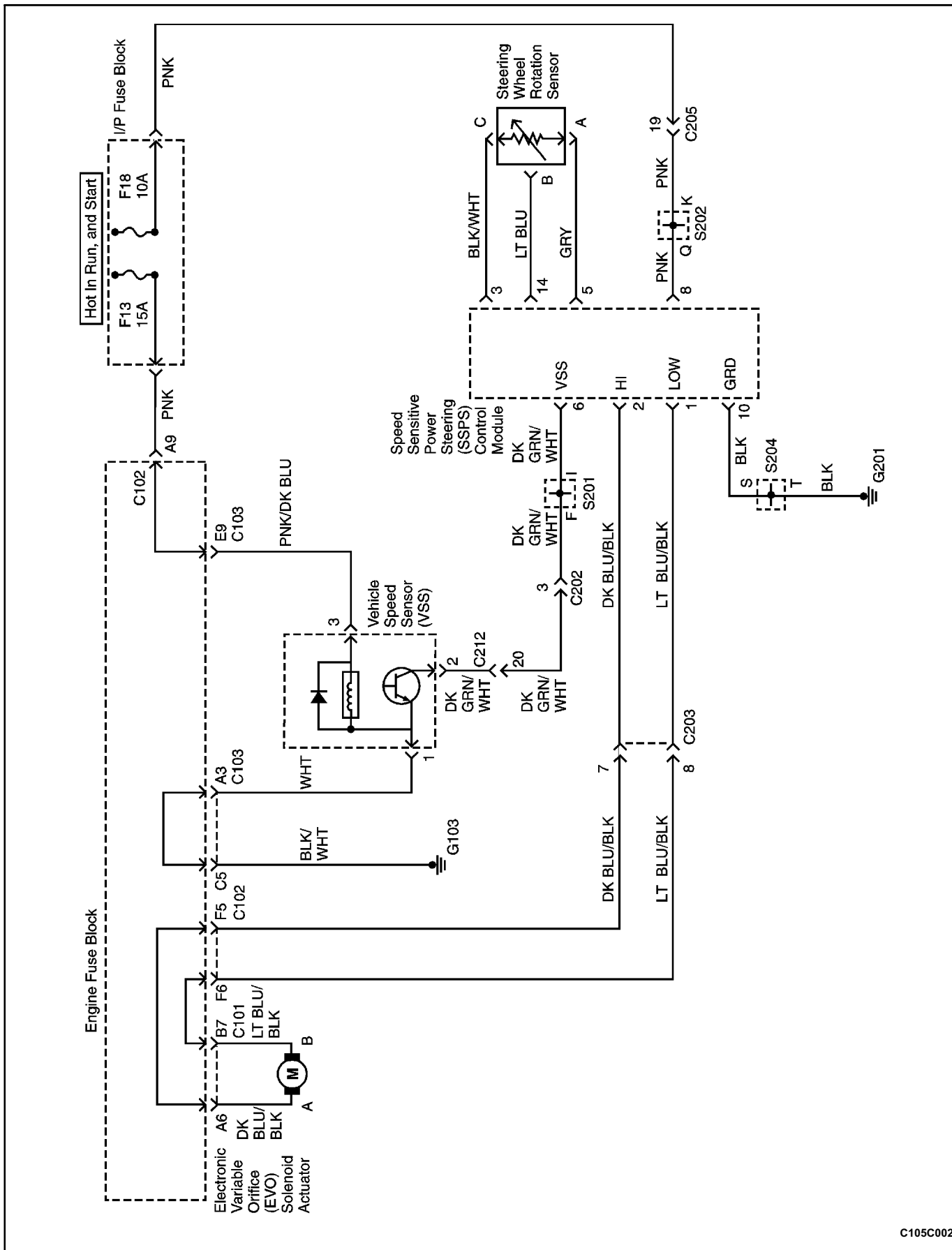

C105C002

## SPEED SENSITIVE POWER STEERING SYSTEM OPERATING WITH FULL ASSIST AT ALL TIMES

Step	Action	Value(s)	Yes	No
1	Perform an initial inspection of the power steering system. Is the system operational?	-	Go to Step 2	Go to Section 6A, Power Steering System
2	Check the speedometer. Is the speedometer inoperative?	-	Go to Section 5, Transaxle	Go to Step 3
3	Check the diagnostic trouble codes at the engine control module (ECM). Is the ECM code 24 set?	-	Go to Section 1F, Engine Controls	Go to Step 4
4	1. Turn the ignition ON. 2. Disconnect the electronic variable orifice (EVO) solenoid actuator electrical connector at the power steering pump. 3. Probe terminal A of the EVO actuator connector with a voltmeter. Does the voltmeter display the specified value?	≈ 3 V	Go to Step 6	Go to Step 5
5	Repair the open or short in the circuit between terminal A of the EVO solenoid actuator electrical connector and terminal 2 on the speed sensitive power steering (SSPS) control module connector. Is the repair complete?	-	System OK	-
6	1. Remove the EVO solenoid actuator from the power steering pump. 2. Turn the actuator upside down to position the pintle. 3. Stimulate the actuator by connecting it to the battery. Does the actuator click?	-	Go to Step 8	Go to Step 7
7	Replace the EVO solenoid actuator. Is the repair complete?	-	System OK	-
8	1. Turn the ignition OFF. 2. Remove the SSPS control module from the control module bracket. 3. Disconnect the SSPS control module connector. 4. Connect a test light from terminal 8 on the SSPS control module connector to the ground. 5. Turn the ignition ON. Is the test light on?	-	Go to Step 14	Go to Step 9
9	Check the ignition fuse. Is the ignition fuse open?	-	Go to Step 10	Go to Step 11
10	Replace the ignition fuse. Is the repair complete?	-	System OK	-
11	Check for an open or short in the circuit between terminal 8 of the control module connector and the I/P fuse block. Is the connection faulty?	-	Go to Step 12	Go to Step 13
12	Repair the open or short in the circuit between terminal 8 of the SSPS control module connector and the I/P fuse block. Is the repair complete?	-	System OK	-

## SPEED SENSITIVE POWER STEERING SYSTEM OPERATING WITH FULL ASSIST AT ALL TIMES (Cont'd)

Step	Action	Value(s)	Yes	No
13	Repair the power feed to the ignition fuse F18. Is the repair complete?	-	System OK	-
14	1. Turn the ignition OFF. 2. Connect a test light from terminal 10 of the SSPS control module connector to B+. Is the test light on?	-	Go to <i>Step 16</i>	Go to <i>Step 15</i>
15	Repair the open in the ground circuit between terminal 10 of the SSPS control module connector and G201. Is the repair complete?	-	System OK	-
16	Check for a short to B+ or an open in the circuit between terminal 1 of the SSPS control module connector and terminal B of the EVO solenoid actuator connector. Is the connection faulty?	-	Go to <i>Step 17</i>	Go to <i>Step 18</i>
17	Repair the short to B+ or an open in the circuit between terminal 1 of the SSPS control module connector and terminal B of the EVO solenoid actuator connector. Is the repair complete?	-	System OK	-
18	1. Disconnect the steering wheel rotation sensor. 2. Turn the ignition ON. 3. Check for an open, short to ground, short to B+, or poor terminal contact between terminal 5 of the SSPS control module connector and terminal A of the steering wheel rotation sensor connector. Is the connection faulty?	-	Go to <i>Step 19</i>	Go to <i>Step 20</i>
19	Repair the open, short to ground, short to B+, or poor terminal contact between terminal 5 of the SSPS control module connector and terminal A of the steering wheel rotation sensor connector. Is the repair complete?	-	System OK	-
20	Check for an open between terminal 3 of the SSPS control module connector and terminal C of the steering wheel rotation sensor connector. Is the connection faulty?	-	Go to <i>Step 21</i>	Go to <i>Step 22</i>
21	Repair the open between terminal 3 of the SSPS control module connector and terminal C of the steering wheel rotation sensor connector. Is the repair complete?	-	System OK	-
22	Check for an open, short to ground, short to B+, or poor terminal contact between terminal 14 of the SSPS control module connector and terminal B of the steering wheel rotation sensor connector. Is the connection faulty?	-	Go to <i>Step 23</i>	Go to <i>Step 24</i>
23	Repair the open, short to ground, short to B+, or poor terminal contact between terminal 14 of the SSPS control module connector and terminal B of the steering wheel rotation sensor connector. Is the repair complete?	-	System OK	-



## SPEED SENSITIVE POWER STEERING SYSTEM OPERATING WITH FULL ASSIST AT ALL TIMES (Cont'd)

Step	Action	Value(s)	Yes	No
24	1. Turn the ignition OFF. 2. Connect the SSPS control module. 3. Connect the steering wheel rotation sensor. 4. Turn the ignition ON. 5. Backprobe with a voltmeter from terminal 5 on the control module connector to the ground. 6. Rotate the steering wheel quickly in both directions. Does the voltage show an increase and decrease from the specified value?	≈ 3 V	Go to <i>Step 25</i>	Go to <i>Step 26</i>
25	Replace the SSPS control module. Is the repair complete?	-	System OK	-
26	Replace the steering wheel rotation sensor. Is the repair complete?	-	System OK	-

## SPEED SENSITIVE POWER STEERING SYSTEM OPERATING WITH DECREASED ASSIST AT ALL TIMES

Step	Action	Value(s)	Yes	No
1	Check the speedometer. Is speedometer inoperative?	-	Go to <i>Section 5, Transaxle</i>	Go to <i>Step 2</i>
2	Disconnect the EVO solenoid actuator at the power steering pump. Is the symptom still present?	-	Go to <i>Section 6A, Power Steering System</i>	Go to <i>Step 3</i>
3	Replace the speed sensitive power steering (SSPS) control module. Is repair complete?	-	System OK	-

## MAINTENANCE AND REPAIR ON-VEHICLE SERVICE RACK AND PINION ASSEMBLY

(Left-Hand Drive Shown, Right-Hand Drive Similar)

### Tools Required

KM-507-B Ball Joint Remover

### Removal Procedure

1. Disconnect the negative battery cable.
2. Raise and suitably support the vehicle.
3. Remove the wheels. Refer to *Section 2E, Tires and Wheels*.
4. Disconnect the power steering gear fluid outlet pipe. Place a drain pan under the steering gear to catch the power steering fluid.
5. Disconnect the power steering gear fluid inlet pipe.

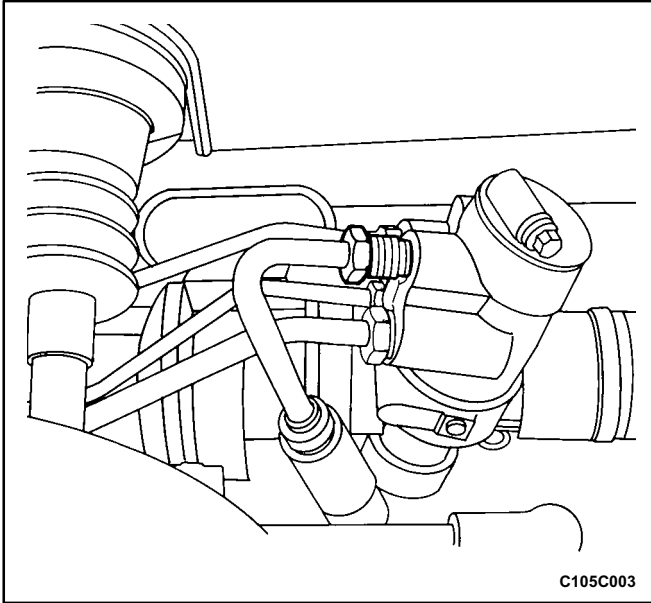

C105C003

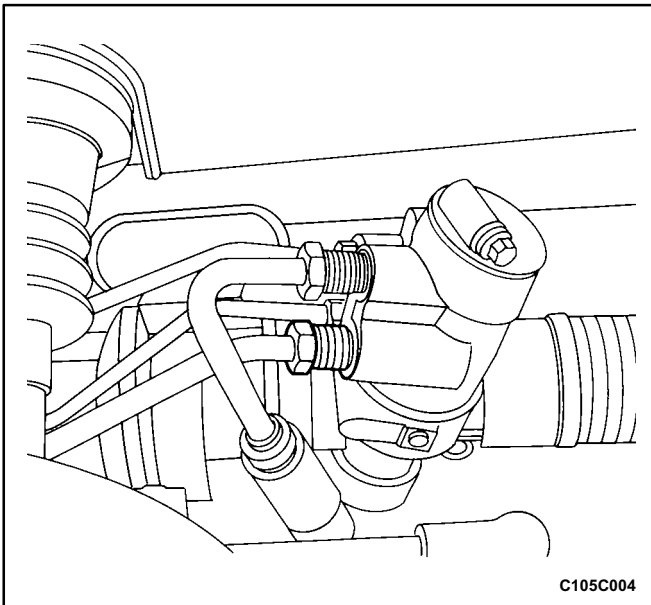

C105C004

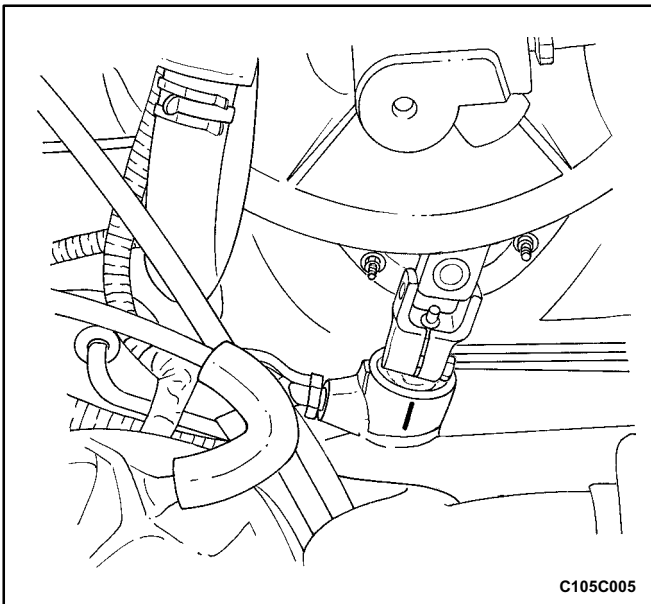

C105C005

6. Position the steering gear straight ahead by turning the steering wheel until the steering wheel spokes are vertical and pointed to the left.
7. Scribe a mark on the stub shaft housing that lines up with a mark on the intermediate shaft lower coupling.

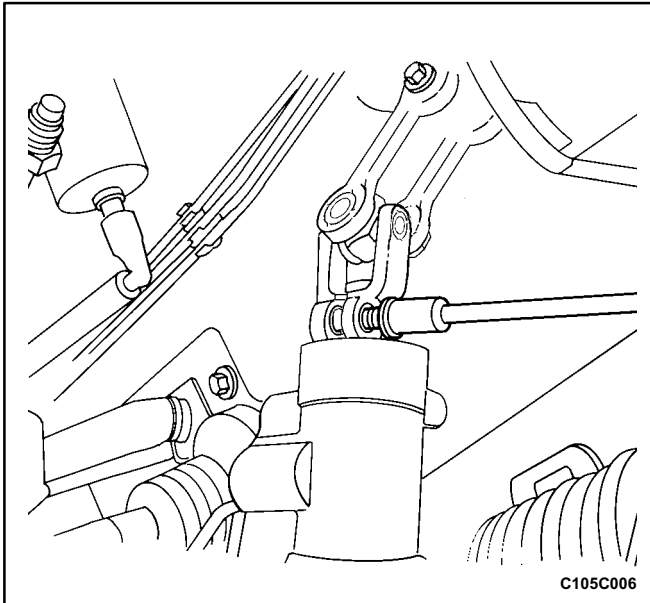

8. Remove the intermediate shaft pinch bolt.

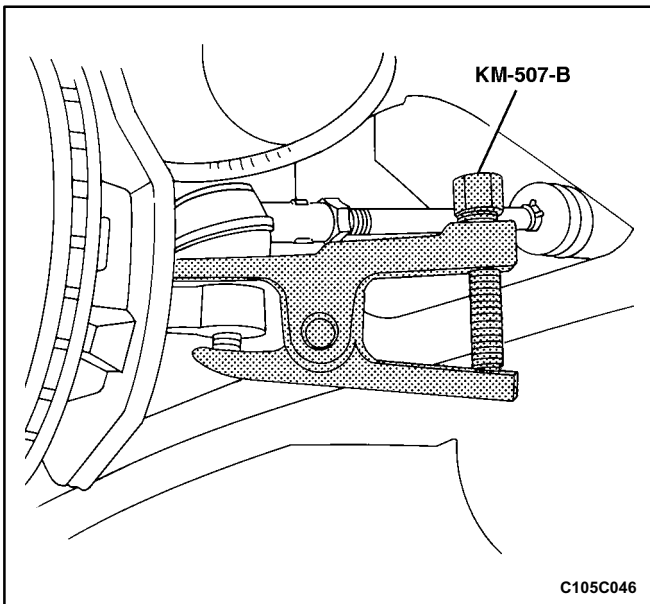

9. Remove the outer tie rod nuts and disconnect the tie rod ends from the strut assembly using the ball joint remover KM-507-B.

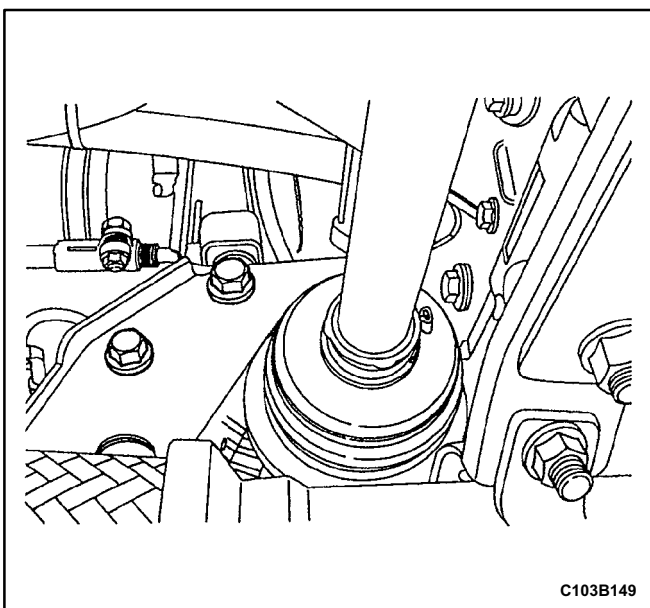

10. Remove the center member. Refer to *Section 9N, Frame and Underbody*.
11. On vehicles equipped with an automatic transaxle, remove the transaxle center bracket. Refer to *Section 5A, ZF 4 HP 14 Automatic Transaxle*.
12. On vehicles equipped with a manual transaxle, remove the bolts securing the transaxle center bracket to the transaxle and the engine. Move the transaxle center bracket out of the way.

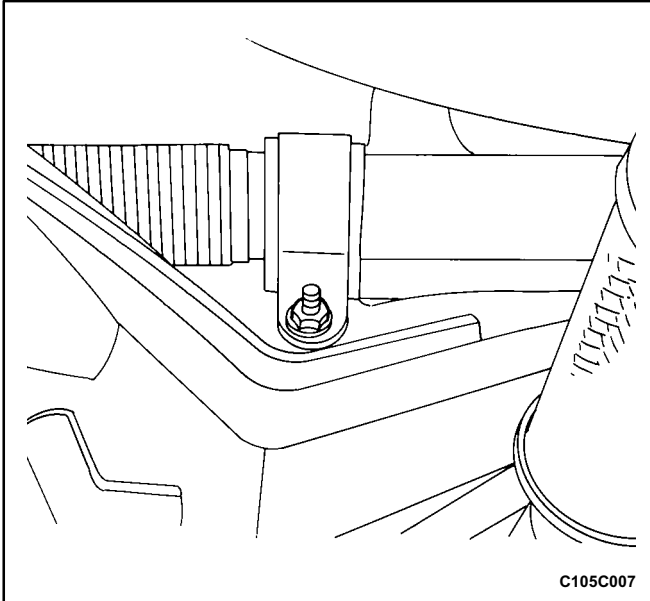

13. Remove the nuts from the steering gear mounting brackets.

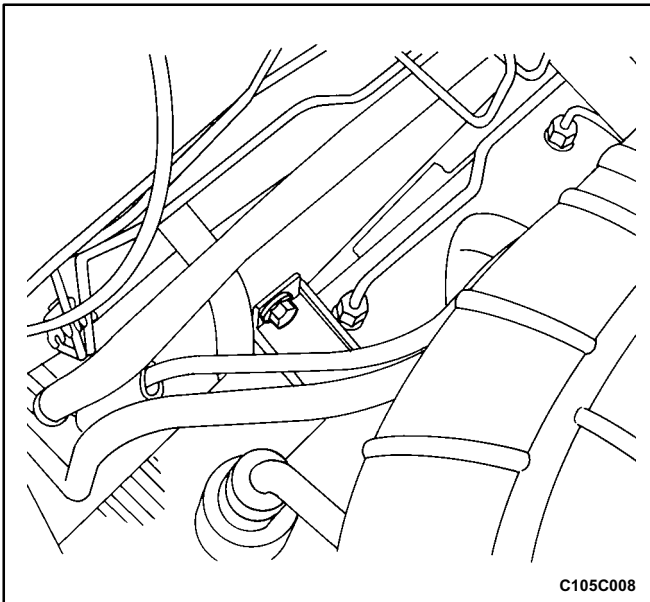

14. Remove the bolts from the steering gear mounting brackets.
15. Disconnect the rack and pinion assembly from the mounts and move it to the right. Bring the assembly out of the vehicle from below.

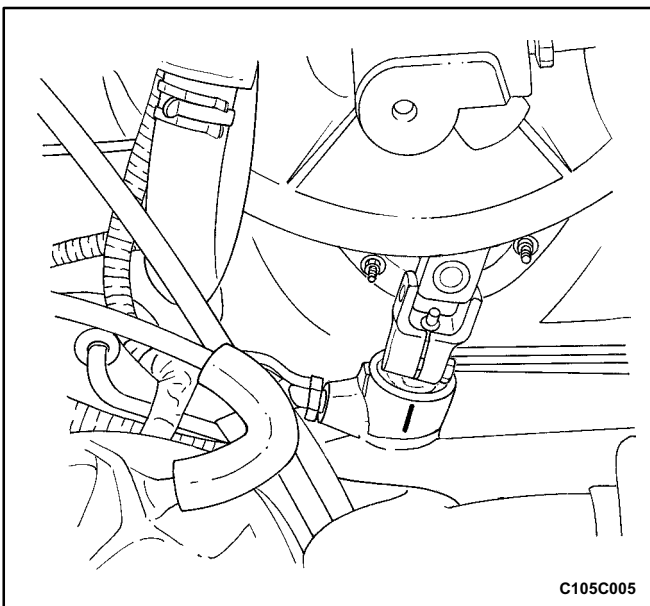

### Installation Procedure

1. Install the rack and pinion assembly from below. The steering gear must be in a straight ahead position, and the steering wheel spokes must be vertical and pointing to the left. Align the marks on the shafts to ensure proper positioning. Seat the stub shaft into the intermediate shaft.

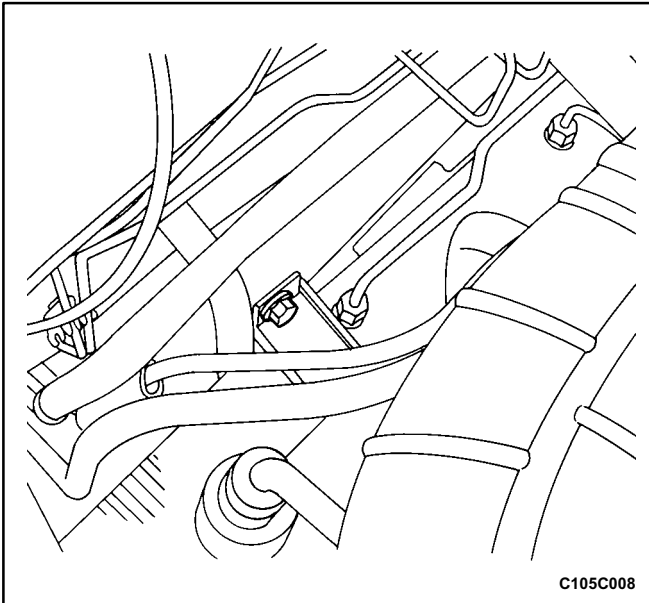

C105C008

2. Install the bolts on the upper part of the steering gear mounting brackets.

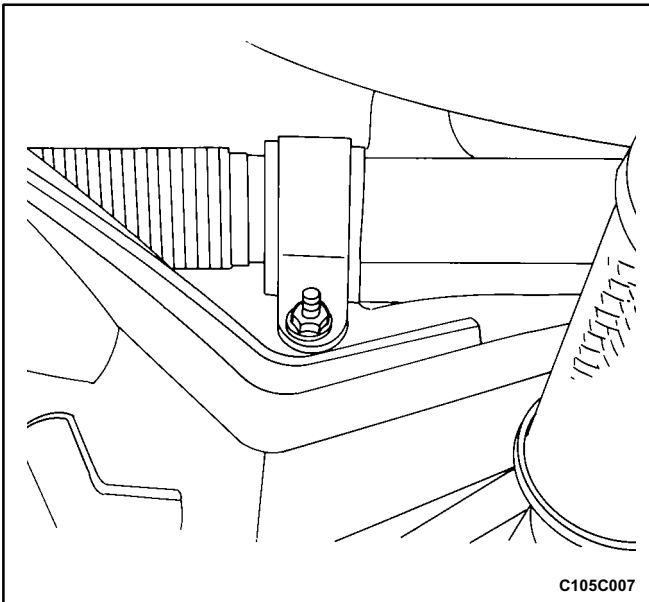

C105C007

3. Install the nuts on the lower part of the steering gear mounting bracket.

### Tighten

Tighten the steering gear mounting bracket bolts and nuts to 60 N•m (44 lb•ft).

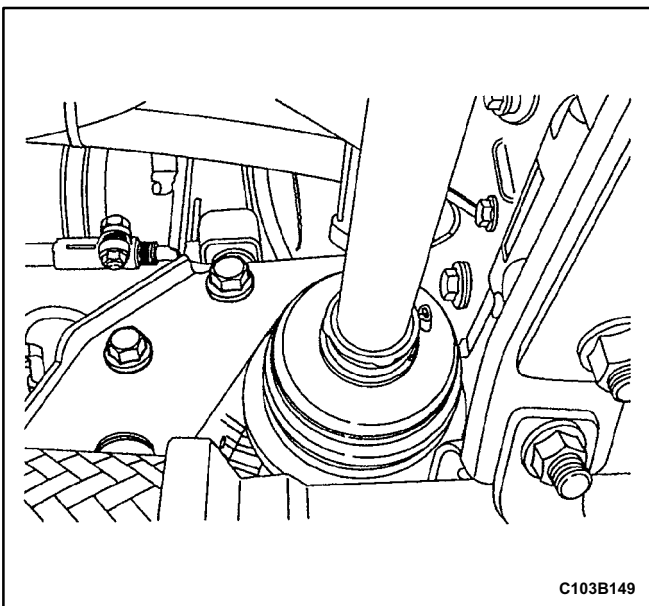

C103B149

4. On vehicles equipped with a manual transaxle, position the transaxle center bracket in place and install the bolts securing the bracket to the engine and the transaxle.

### Tighten

Tighten the transaxle center bracket to transaxle bolts and the transaxle center bracket to engine bolt to 90 N•m (66 lb•ft).

5. On vehicles equipped with an automatic transaxle, install the transaxle center bracket. Refer to *Section 5A, ZF 4 HP 14 Automatic Transaxle*.
6. Install the center member. Refer to *Section 9N, Frame and Underbody*.

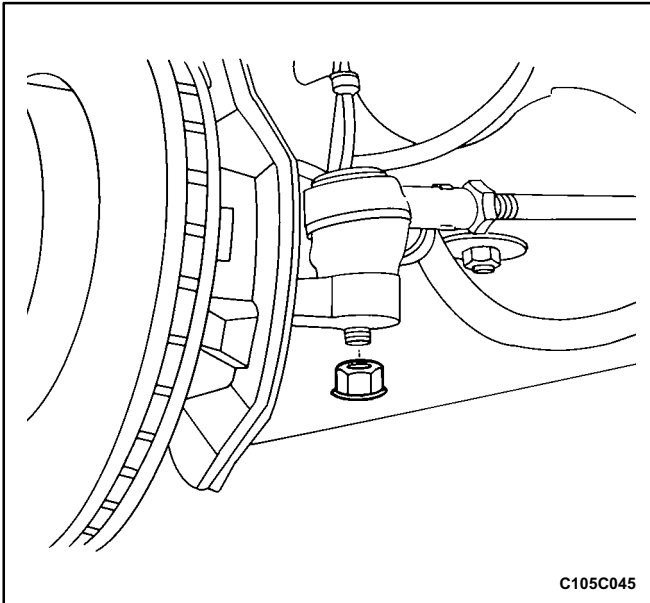

7. Connect the tie rod ends to the strut assembly.
8. Install the outer tie rod nuts.

**Tighten**

Tighten the outer tie rod nuts to 50 N•m (37 lb•ft).

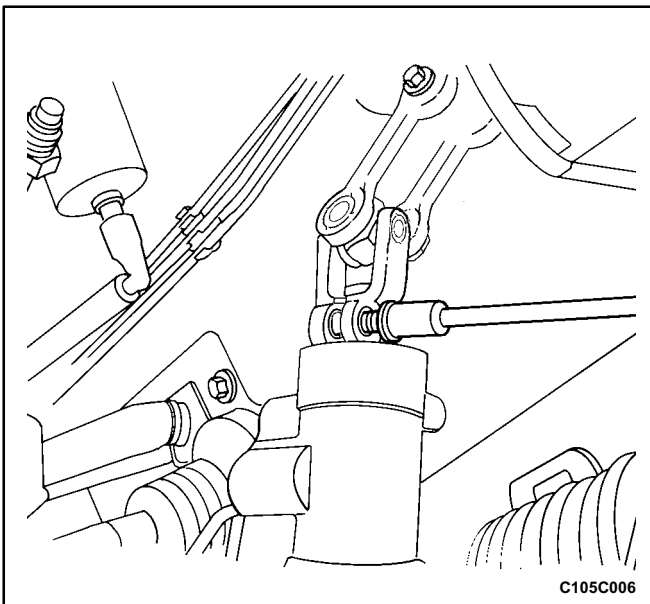

9. Install the lower intermediate shaft pinch bolt.

**Tighten**

Tighten the lower intermediate shaft pinch bolt to 25 N•m (18 lb•ft).

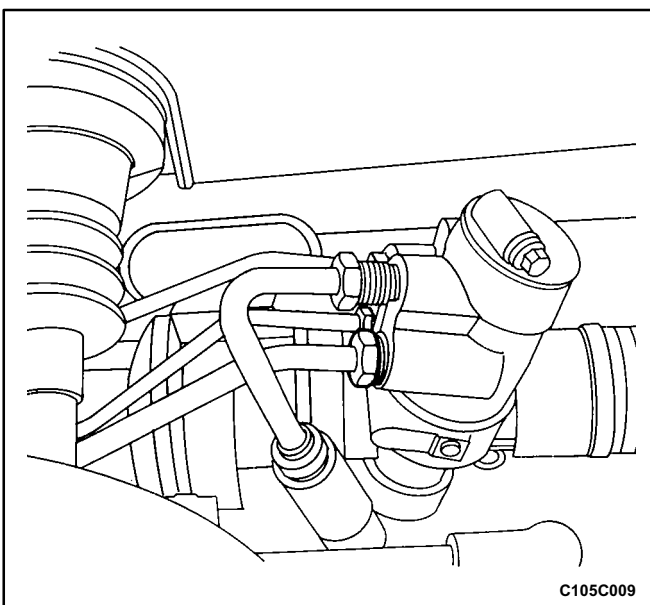

10. Connect the power steering gear fluid inlet pipe.

**Tighten**

Tighten the steering gear inlet pipe fitting to 28 N•m (21 lb•ft).

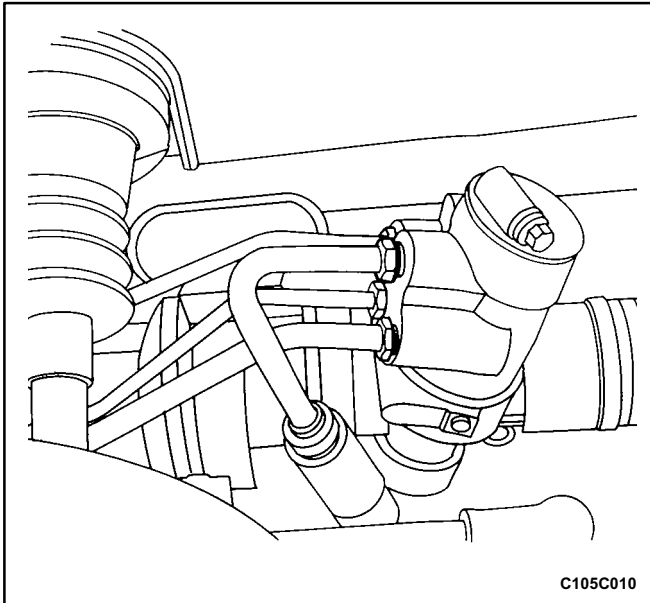

11. Connect the power steering gear fluid outlet pipe.

### Tighten

Tighten the steering gear outlet pipe fitting to 28 N•m (21 lb•ft).

12. Install the wheels. Refer to *Section 2E, Tires and Wheels*.
13. Lower the vehicle.
14. Do a straight ahead check. Refer to „Straight Ahead Check” in this section.

**Notice:** When adding fluid or making a complete fluid change, always use power steering fluid DEXRON® II or III or equivalent. Failure to use the proper fluid will cause hose and seal damage and fluid leaks.

15. Refill the power steering system and check for leaks. If leaks are found, correct the cause of the leak and bleed the system. Refer to *Section 6A, Power Steering System*.
16. Connect the negative battery cable.

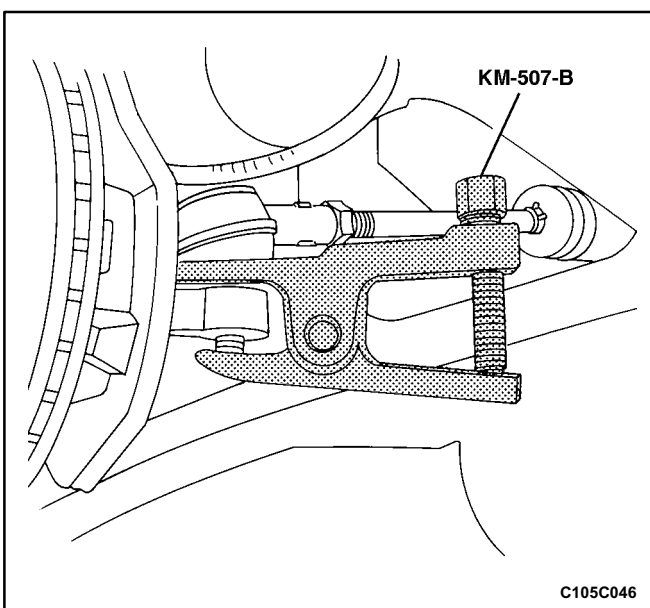

## OUTER TIE ROD

### Tools Required

KM-507-B Ball Joint Remover

### Removal Procedure

1. Remove the wheel. Refer to *Section 2E, Tires and Wheels*.
2. Mark the threads on the inner tie rod to aid in repositioning the adjusting nut.
3. Remove the outer tie rod nut and disconnect the outer tie rod from the steering knuckle using the ball joint remover KM-507-B.

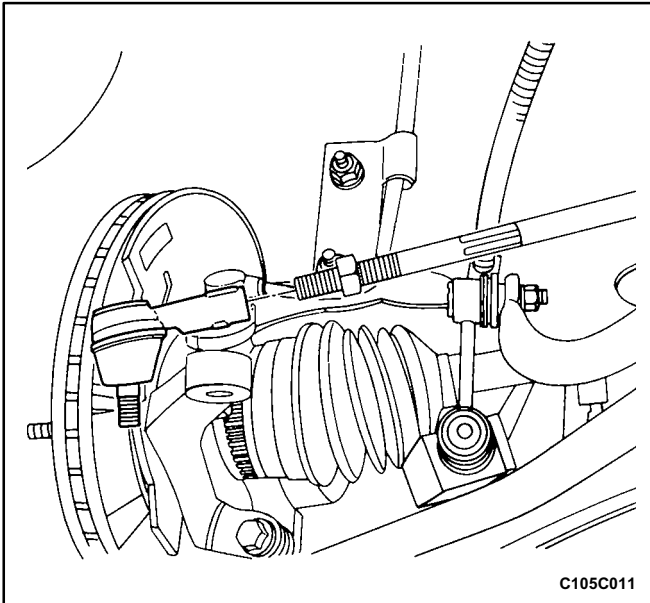

4. Loosen the outer tie rod adjusting nut and remove the outer tie rod by twisting it off the inner tie rod.

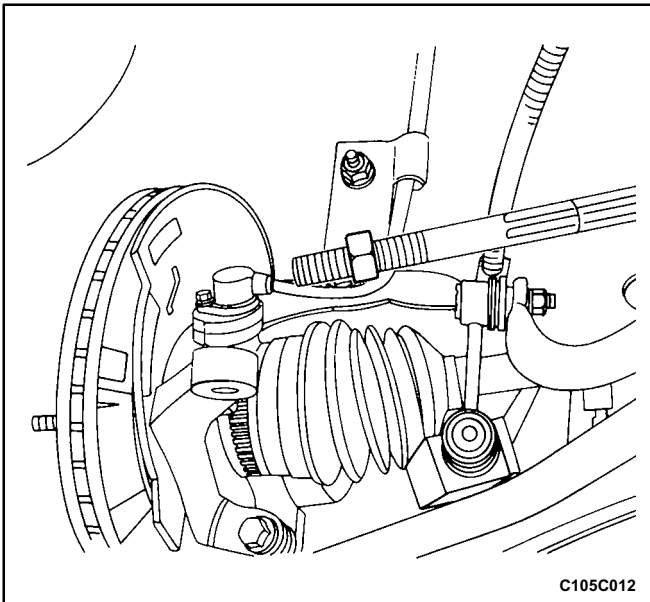

### Installation Procedure

1. Reposition the adjusting nut to the marks on the inner tie rod.

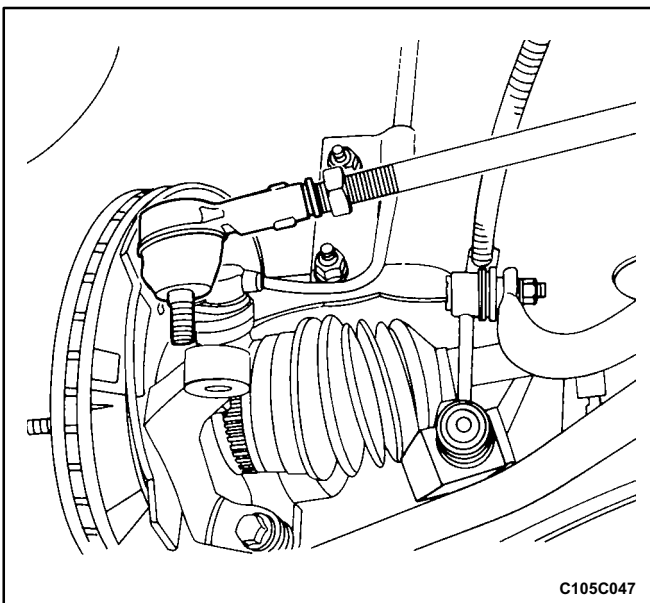

2. Install the outer tie rod by twisting it onto the inner tie rod.



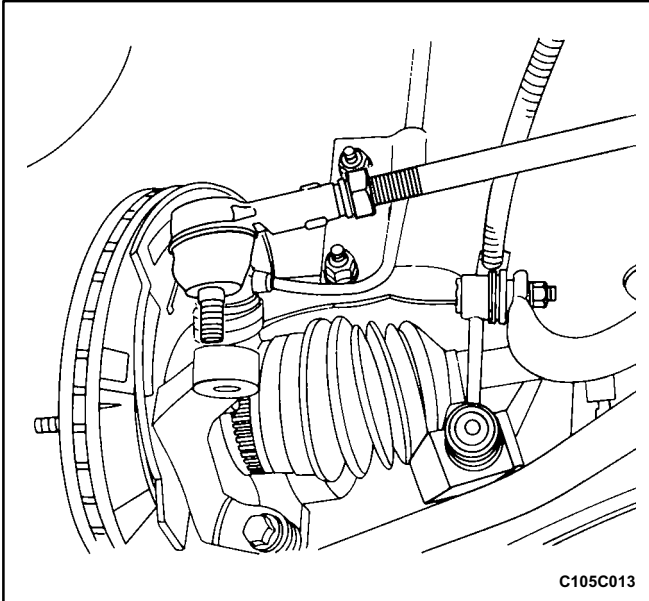

C105C013

3. Connect the outer tie rod to the steering knuckle.
4. Perform a front toe adjustment. Refer to *Section 2B, Wheel Alignment*.
5. Tighten the adjusting nut.

### **Tighten**

Tighten the outer tie rod adjusting nut to 64 N•m (47 lb•ft).

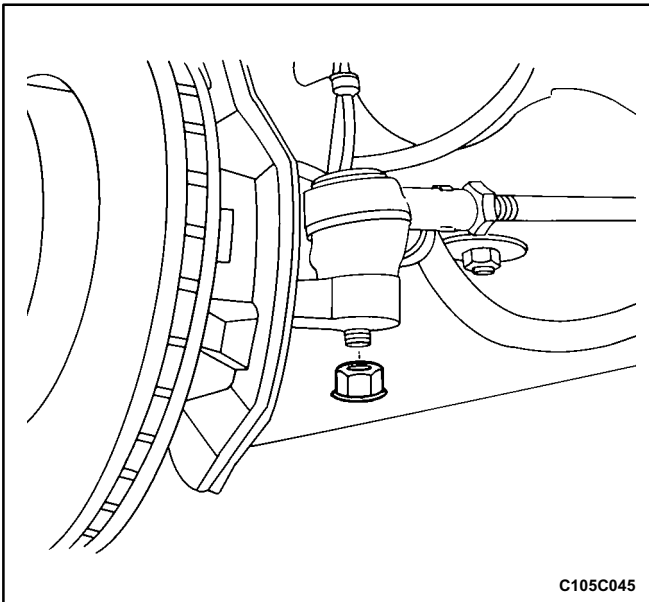

C105C045

6. Install the outer tie rod nut.

### **Tighten**

Tighten the outer tie rod nut to 50 N•m (37 lb•ft).

7. Install the wheel. Refer to *Section 2E, Tires and Wheels*.

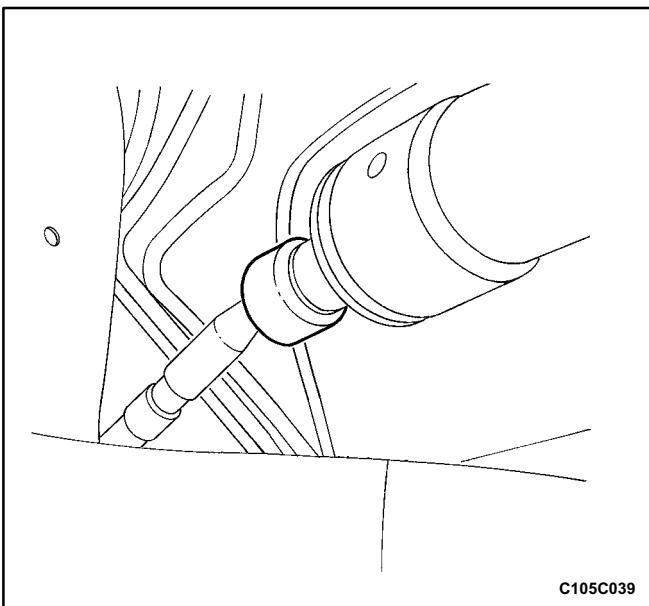

C105C039

## **INNER TIE ROD**

### **Removal Procedure**

1. Raise and suitably support the vehicle.
2. Remove the wheel. Refer to *Section 2E, Tires and Wheels*.
3. Remove the outer tie rod. Refer to „Outer Tie Rod” in this section.
4. Remove the dust boot. Refer to „Dust Boot” in this section.
5. Push back the plastic retainer protecting the connection between the inner tie rod and the power steering gear rack.

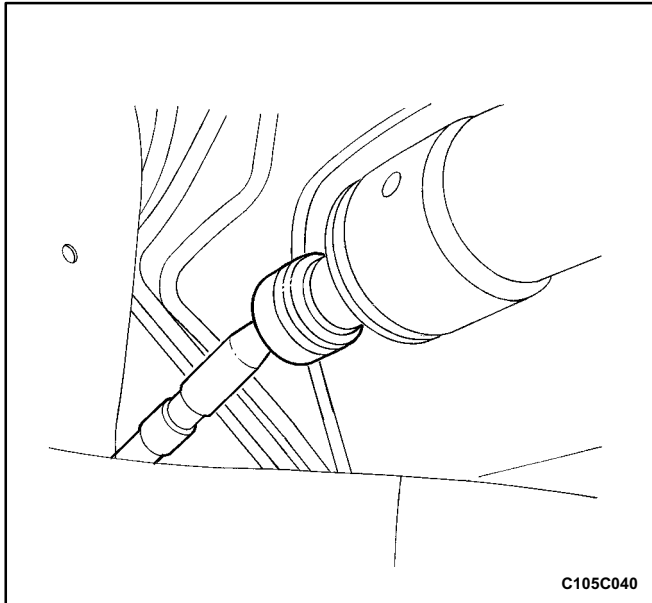

6. Remove the inner tie rod.

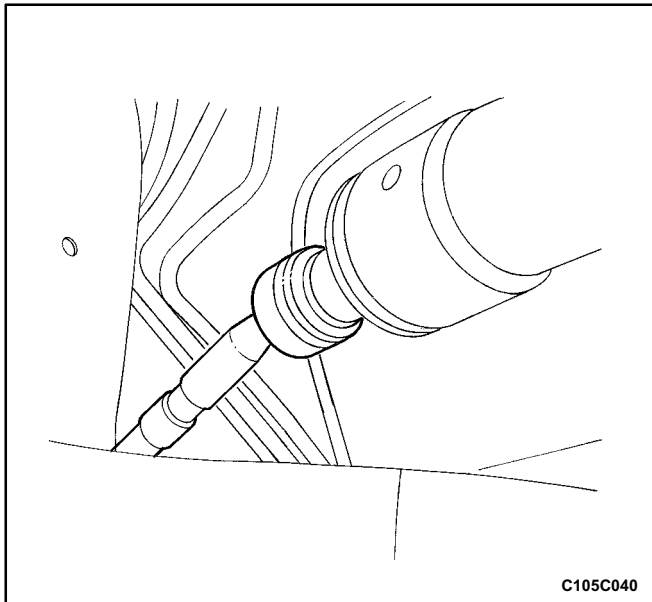

### Installation Procedure

**Important:** The right and left inner tie rods are unequal in length. Be sure to install the correct inner tie rod on the proper side of the power steering gear.

1. Install the inner tie rod.

#### Tighten

Tighten the inner tie rod to 100 N•m (74 lb•ft).

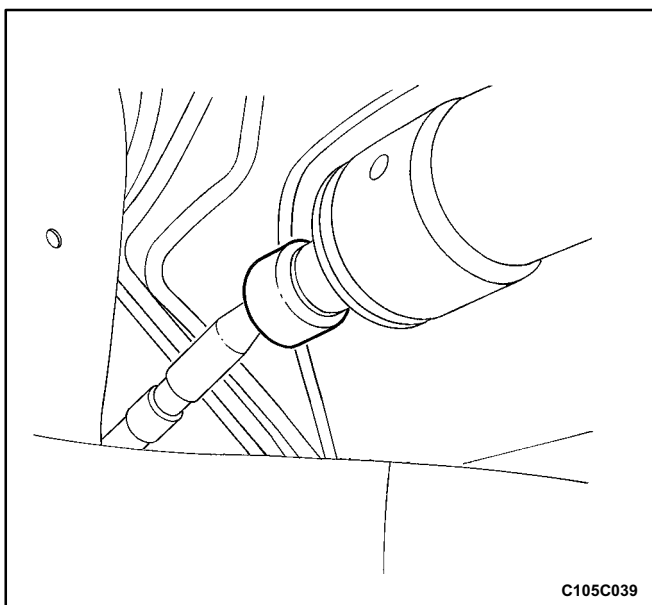

2. Push the plastic retainer over the tie rod.
3. Install the dust boot. Refer to „Dust Boot” in this section.
4. Install the outer tie rod. Refer to „Outer Tie Rod” in this section.
5. Install the wheel. Refer to *Section 2E, Tires and Wheels*.
6. Lower the vehicle.

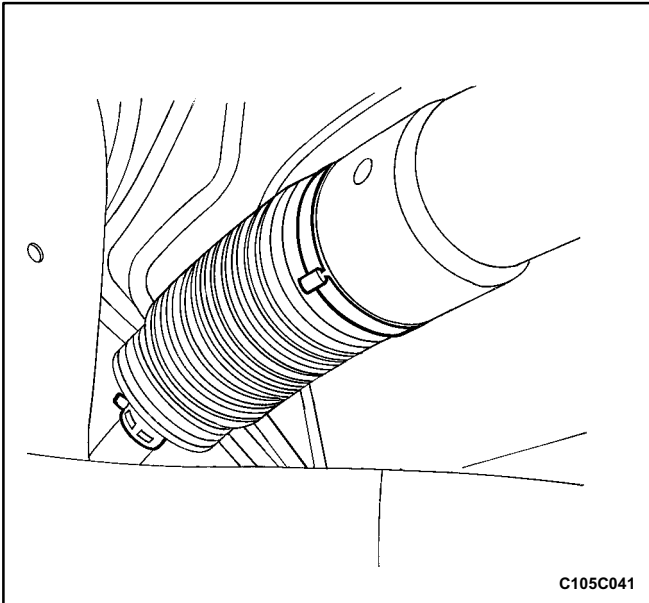

## DUST BOOT

### Tools Required

KM-J-22610 Installer

### Removal Procedure

1. Raise and suitably support the vehicle
2. Remove the wheel. Refer to *Section 2E, Tires and Wheels*.
3. Remove the outer tie rod. Refer to „Outer Tie Rod” in this section.
4. Remove the dust boot retaining clamps.

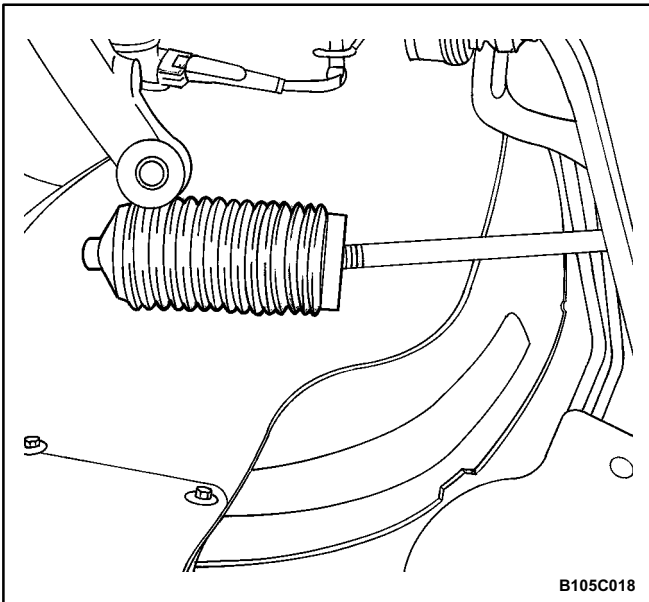

5. Remove the dust boot.

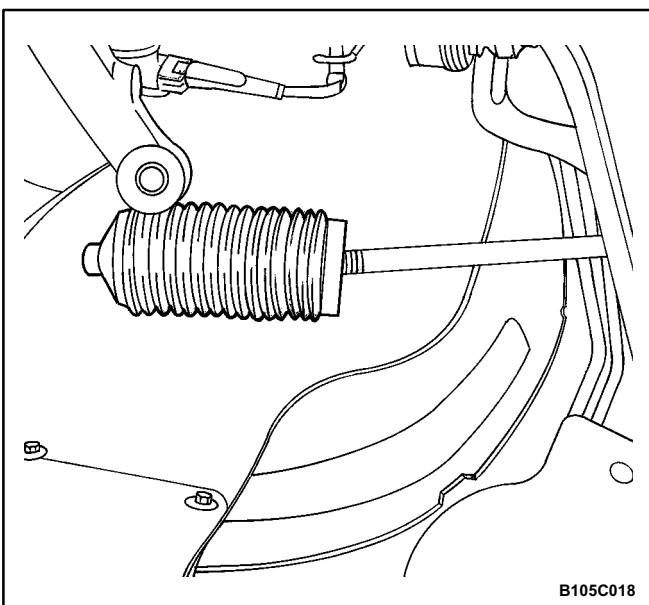

### Installation Procedure

1. Install the dust boot.

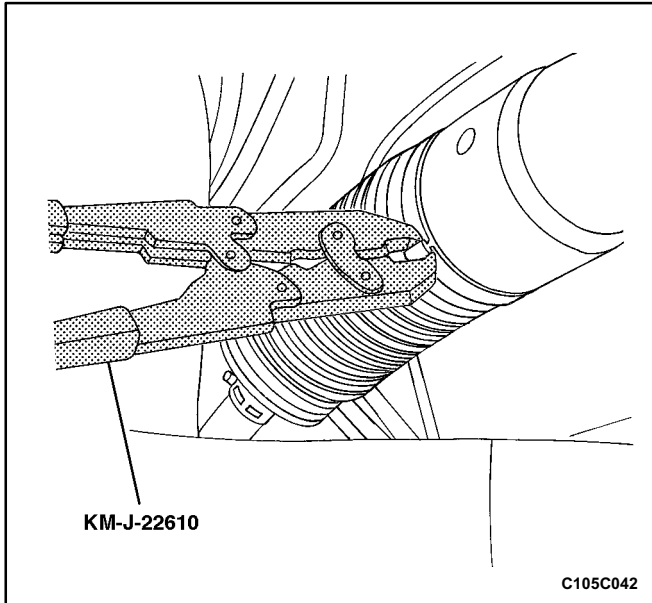

2. Install the tie rod end dust boot retaining clamp. Install the cylinder end dust boot retaining clamp with the installer KM-J-22610.
3. Install the outer tie rod. Refer to „Outer Tie Rod” in this section.
4. Install the wheel. Refer to *Section 2E, Tires and Wheels*.
5. Lower the vehicle.

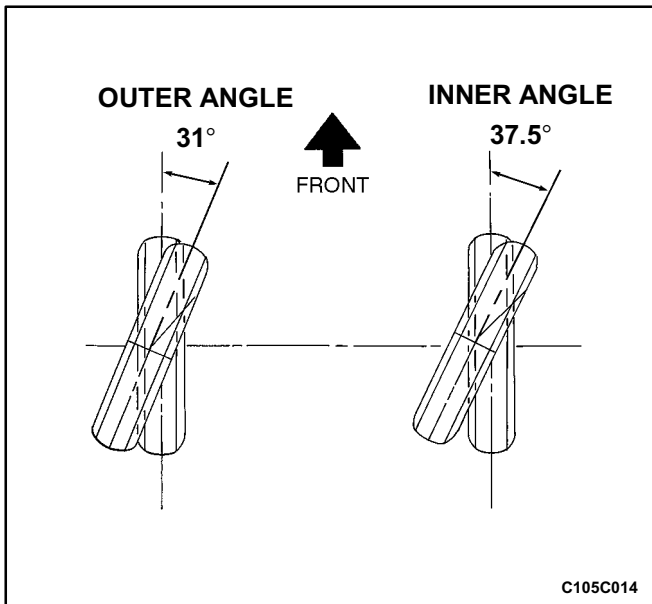

### STRAIGHT AHEAD CHECK

After all the necessary operations on the steering gear are completed (removing and installing, disassembling and assembling), check the exact straight ahead position of the steering in each case.

With the vehicle on the floor, place the steering wheel in the straightahead position. Mark the centerline of both tires on the floor. Turn the steering wheel all the way to the right and mark the new centerline of both tires on the floor.

## StraightAhead Check Table

Step	Action	Value(s)	Yes	No
1	Place the steering wheel in the straight ahead position. Is the wheel in the correct position?	-	Go to Step 2	-
2	Is the lower intermediate shaft pinch bolt lying parallel to the steering gear?	-	Go to Step 3	Go to Step 4
3	Is the steering wheel off center by more than 5 degrees?	-	Go to Step 5	Go to Step 6
4	The pinion is displaced on the rack. The steering pinion position must be corrected. Is the repair complete?	-	Go to Step 2	-
5	Remove steering wheel and center on the spindle splines. Is the repair complete?	-	Go to Step 3	-
6	Turn the steering wheel all the way to the right. Measure the inner and the outer angles of the tire centerline compared to the straight ahead centerline. Are the angles within specifications?	Inner angle: 37.5° Outer angle: 31°	System OK	Go to Step 7
7	The rack assembly was not assembled correctly. Repair as needed. Is the repair complete?	-	Go to Step 6	-

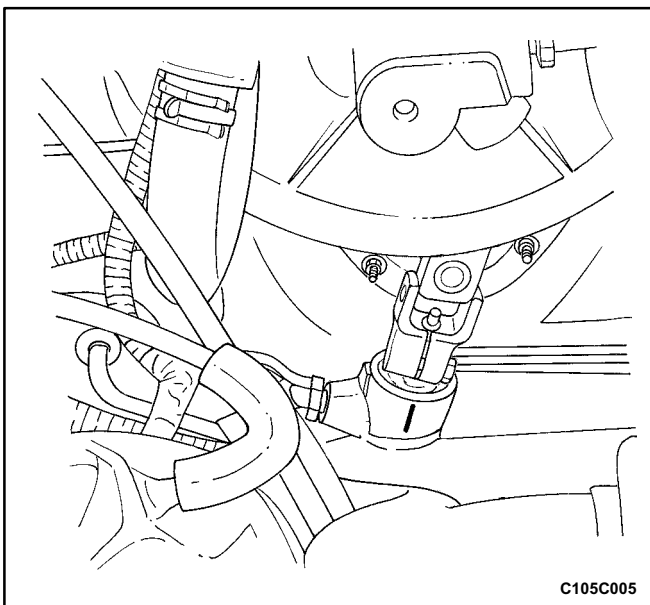

## INTERMEDIATE SHAFT AND DASH SEAL

(Left-Hand Drive Shown, Right-Hand Drive Similar)

### Removal Procedure

1. Turn the steering wheel until it is horizontal, with the spokes pointing down. This is the straight ahead position. Make a mark on the stub shaft housing that lines up with a mark on the intermediate shaft lower universal joint. This mark will be used for proper alignment during installation.

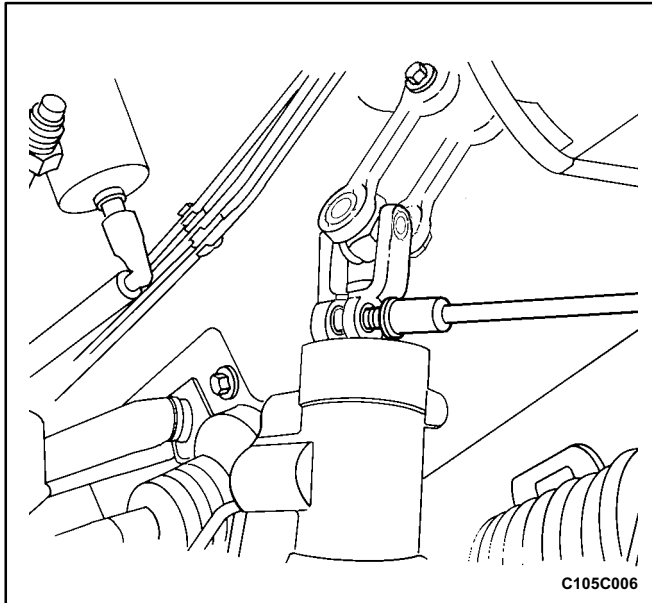

2. Remove the lower pinch bolt from the universal joint on the intermediate shaft.

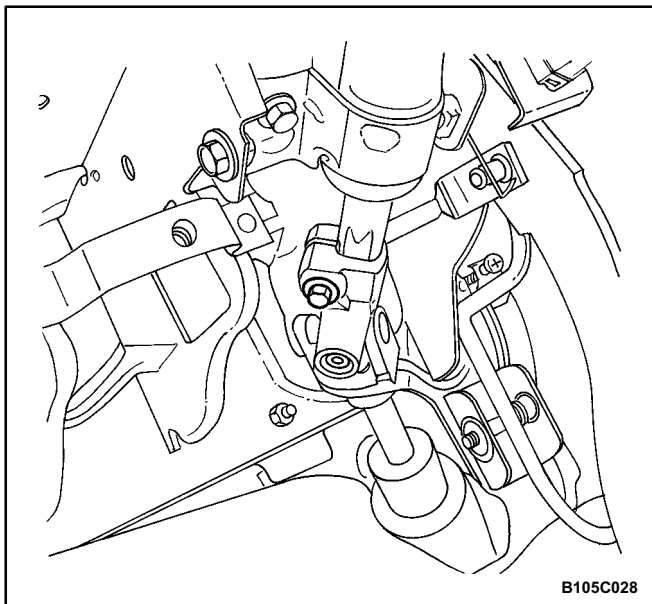

3. Turn the steering wheel so that the upper pinch bolt is accessible. Remove the upper pinch bolt from the universal joint on the intermediate shaft.

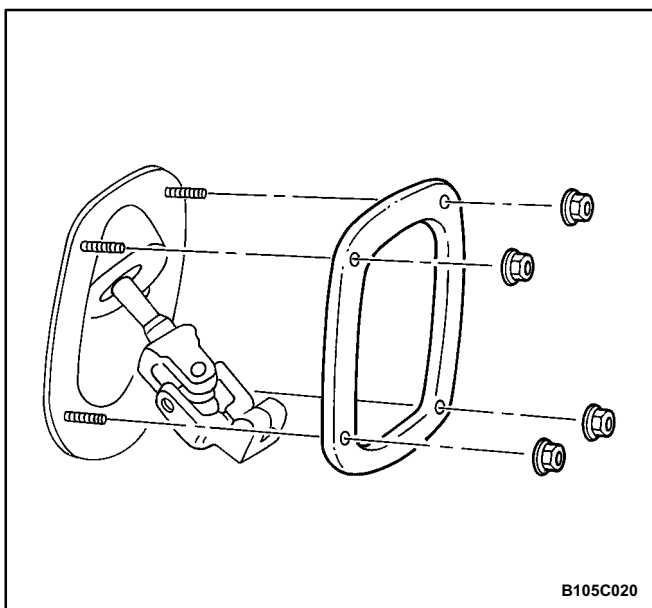

4. Remove the nuts from the dash seal retaining ring and remove the dash seal retaining ring.

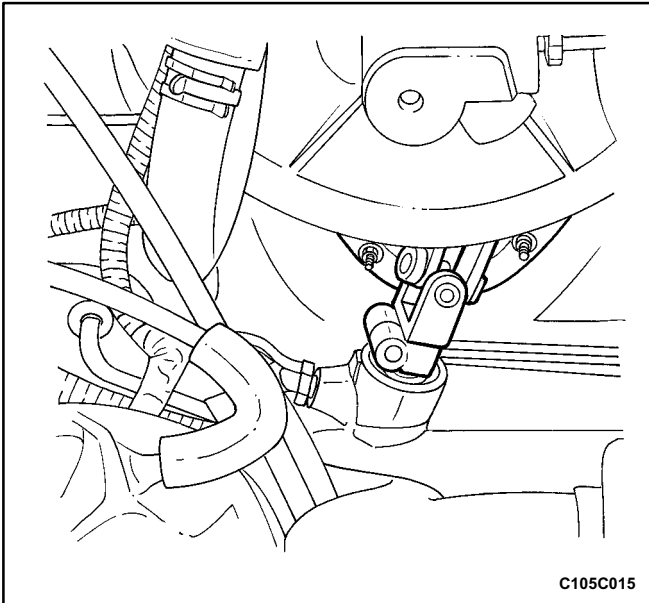

5. Remove the coupling from the power steering gear and pull the intermediate shaft out of the engine compartment.

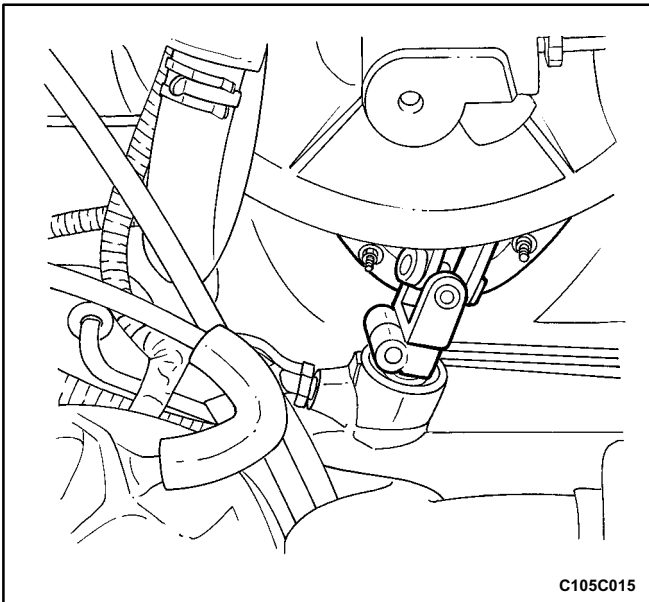

### Installation Procedure

1. Install the intermediate shaft into the vehicle.

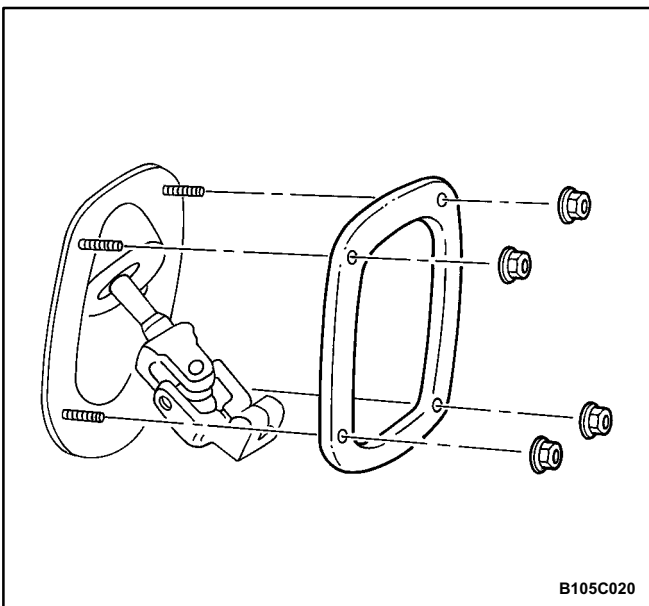

2. Install the dash seal retaining ring with the nuts.

### Tighten

Tighten the dash seal retaining ring nuts to 7 N•m (62 lb•in).

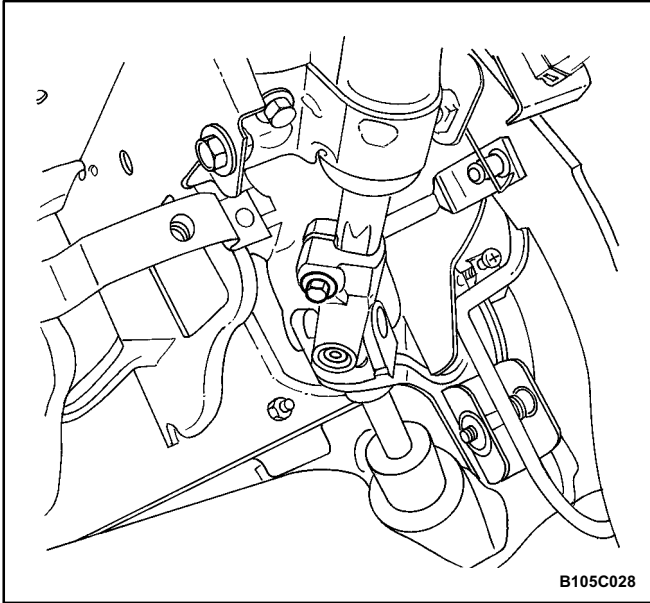

**Important:** When attaching the upper universal joint, the steering wheel must be placed in the straight ahead position with the spokes pointing down.

3. Attach the upper universal joint of the intermediate shaft onto the steering column.
4. Install the pinch bolt into the upper universal joint on the intermediate shaft and tighten the bolt.

**Tighten**

Tighten the upper intermediate shaft pinch bolt to 22 N•m (16 lb•ft).

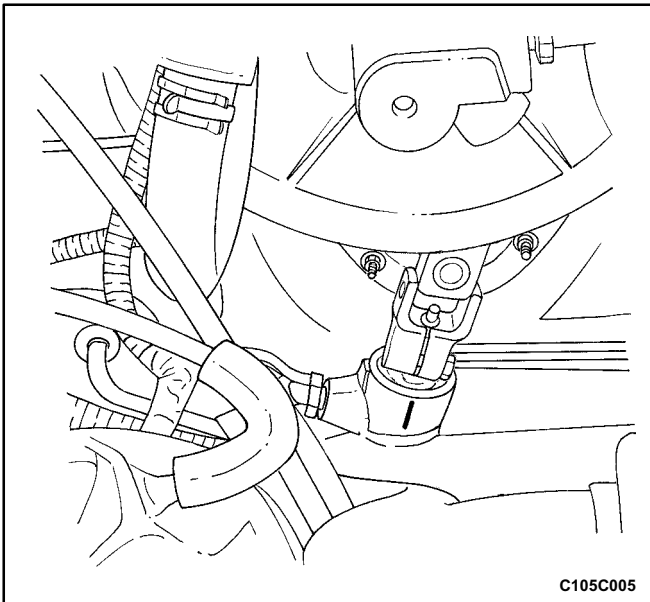

**Important:** When attaching the lower universal joint, the marks on the intermediate shaft and on the stub shaft should line up.

5. Attach the lower universal joint of the intermediate shaft onto the steering gear stub shaft.

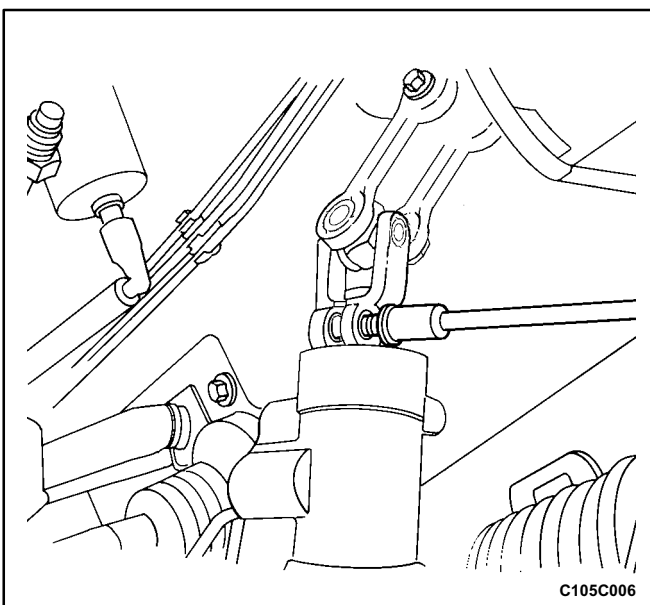

**Important:** When installing the lower intermediate shaft pinch bolt, make sure the bolt goes through the universal joint on the side of the stub shaft with the notch. If you have trouble seating the universal joint completely down onto the stub shaft, rotate the steering wheel slightly while pushing down on the universal joint.

6. Install the bolt into the lower universal joint on the intermediate shaft and tighten the bolt.

**Tighten**

Tighten the lower intermediate shaft pinch bolt to 22 N•m (16 lb•ft).



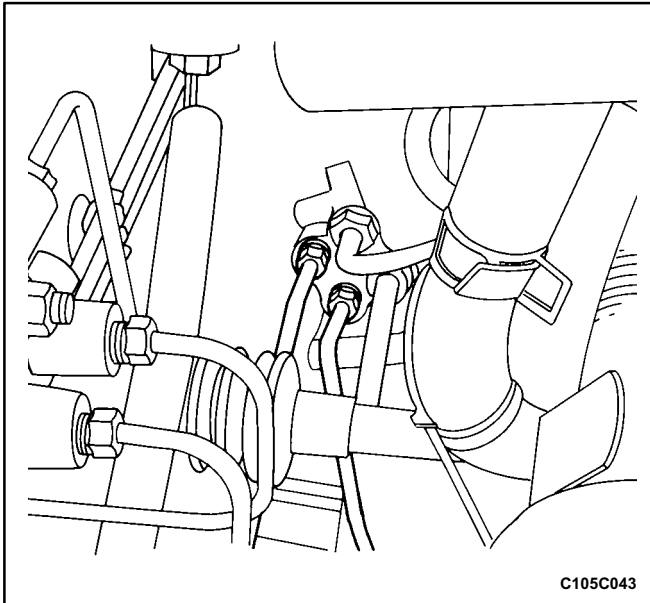

## HYDRAULIC CYLINDER LINES

(Left-Hand Drive-Shown, Right-Hand Drive Similar)

### Removal Procedure

1. Siphon the power steering fluid from the fluid reservoir.
2. Raise and suitably support the vehicle.
3. Disconnect the power steering gear hydraulic cylinder pipes from the power steering gear at the valve end. Replace the O-ring seals as needed.

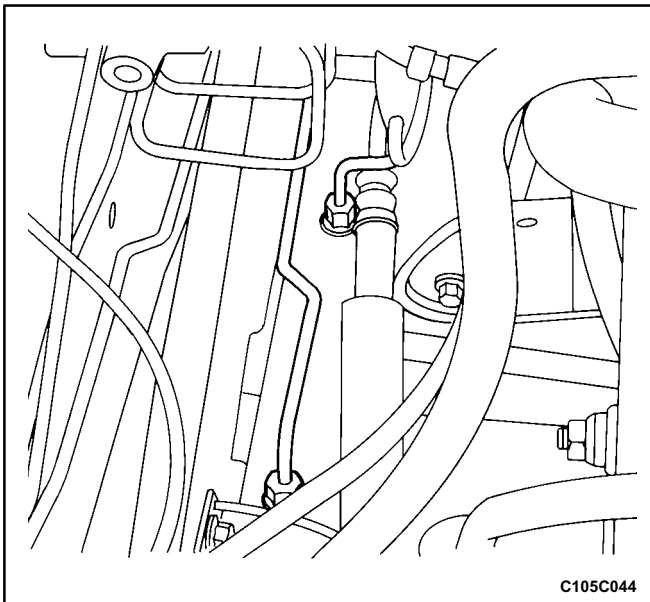

4. Disconnect the power steering gear hydraulic cylinder pipes from the power steering gear at the cylinder end.
5. Remove the steering gear hydraulic cylinder pipes from the vehicle.

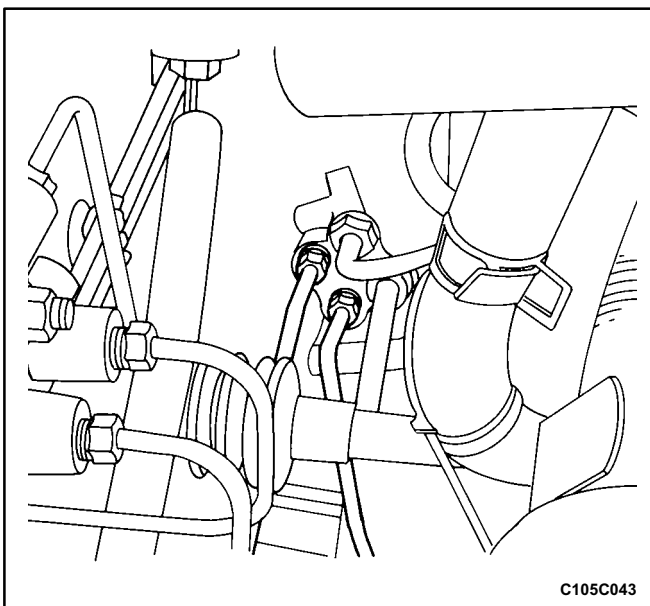

### Installation Procedure

1. Lubricate any new O-ring seals with power steering fluid.
2. Place the O-ring seals into the housing and install the steering gear hydraulic cylinder pipes.
3. Connect the power steering gear hydraulic cylinder pipes to the power steering gear at the valve end.

### Tighten

Tighten the hydraulic cylinder line fittings at the valve end to 18 N•m (13 lb•ft).

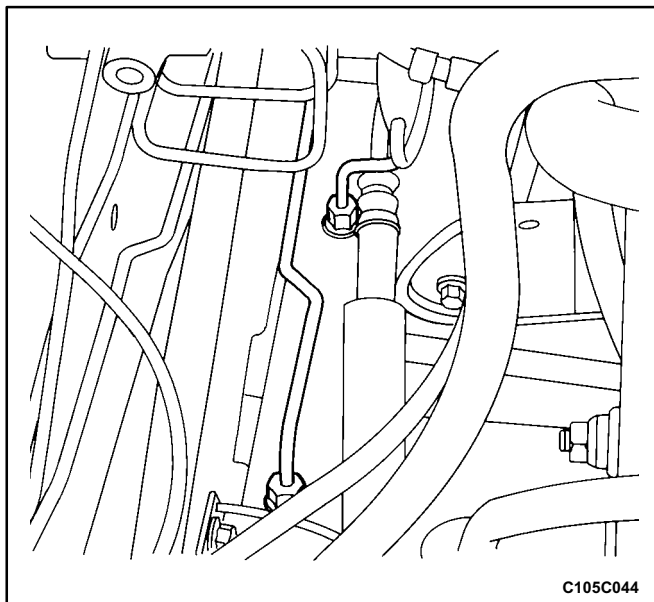

4. Connect the power steering gear hydraulic cylinder pipes to the power steering gear at the cylinder end.

**Tighten**

Tighten the hydraulic cylinder line fittings at the cylinder end to 27 N•m (20 lb•ft).

5. Lower the vehicle.

**Notice:** When adding fluid or making a complete change, always use DEXRON® II or III power steering fluid. Failure to use the proper fluid will cause hose and seal damage and fluid leaks.

6. Fill the fluid reservoir with power steering fluid.
7. Inspect for leaks. If there are leaks, correct the cause of the leaks and bleed the system. Refer to „Bleeding the Power Steering System” in this section.

**SPEED SENSITIVE POWER STEERING CONTROL MODULE**

**Removal Procedure**

1. Disconnect negative battery cable.
2. Remove the ashtray. Refer to *Section 9E, Instrumentation/Driver Information*.
3. Slide the speed sensitive power steering (SSPS) control module off the control module bracket.

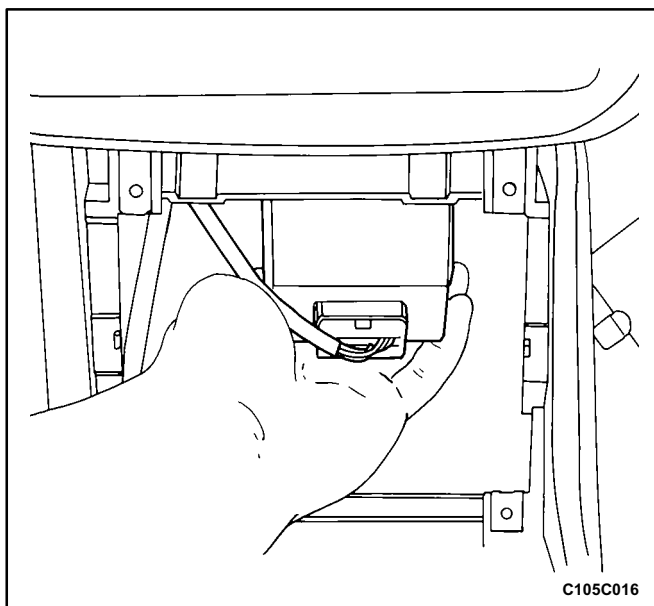

4. Disconnect the electrical connector from the SSPS control module.

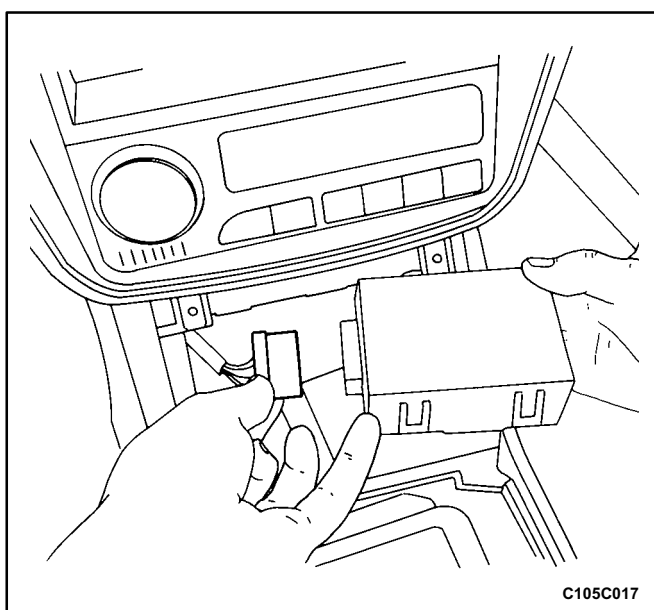

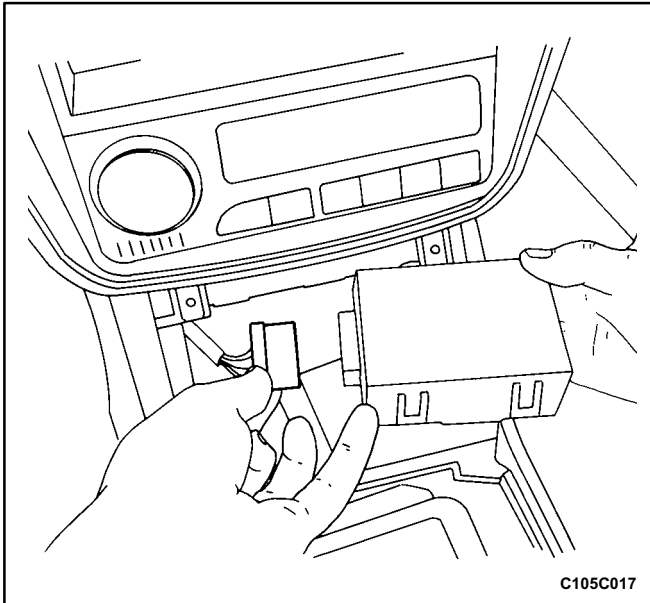

### Installation Procedure

1. Connect the electrical connector to the SSPS control module.
2. Slide the SSPS control module onto the SSPS control module bracket.
3. Install the ashtray. Refer to *Section 9G, Interior Trim*.
4. Connect the negative battery cable.

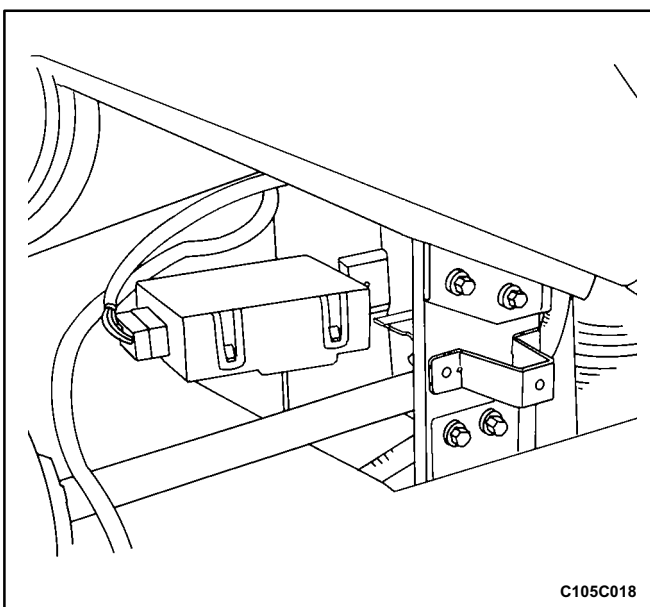
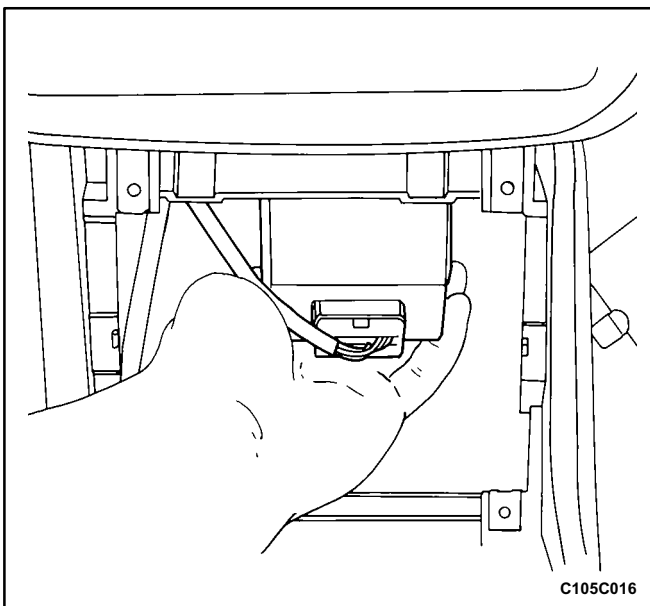

### SPEED SENSITIVE POWER STEERING CONTROL MODULE BRACKET

#### Removal Procedure

1. Disconnect negative battery cable.
2. Remove the floor console. Refer to *Section 9G, Interior Trim*.
3. Slide the speed sensitive power steering (SSPS) control module off the control module bracket.

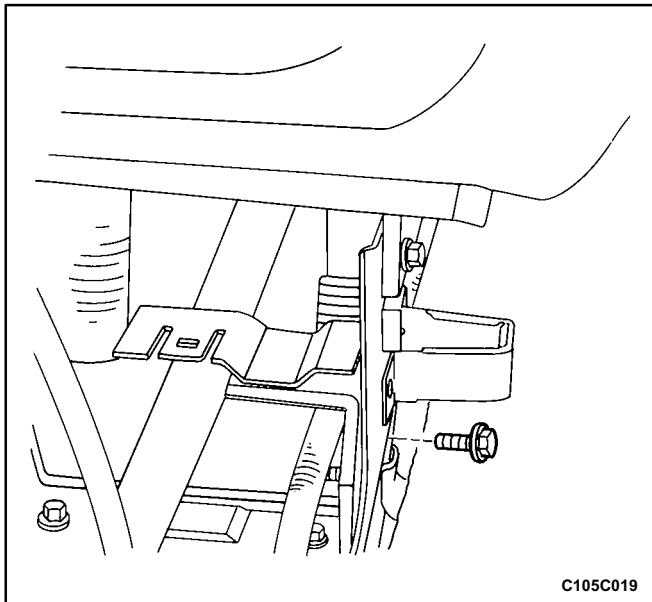

4. Remove the SSPS control module bracket bolts and remove the control module bracket.

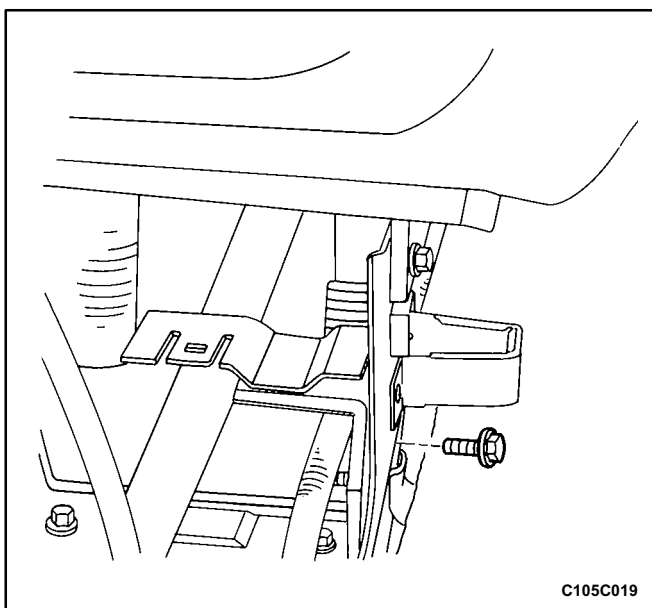

### Installation Procedure

1. Install the SSPS control module bracket and the control module bracket bolts.

### Tighten

Tighten the SSPS control module bracket bolts to 7 N.m (62 lb•in).

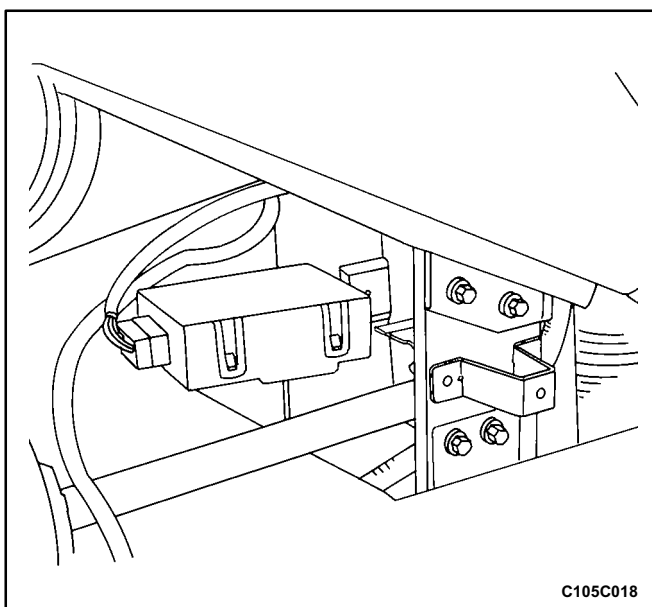

2. Slide the SSPS control module onto the control module bracket.
3. Install the floor console. Refer to *Section 9G, Interior Trim*.
4. Connect the negative battery cable.

## UNIT REPAIR

### RACK AND PINION

#### Tools Required

KM-J-22610 Installer

#### Disassembly Procedure

1. Remove the rack and pinion steering assembly from the vehicle. Refer to „Rack and Pinion Assembly” in this section.
2. Remove the valve and pinion assembly from the rack and pinion steering assembly. Refer to „Valve and Pinion” in this section.
3. Remove the rack bearing assembly from the rack and pinion steering assembly. Refer to „Rack Bearing” in this section.
4. Mark the threads on the inner tie rod to aid in repositioning the adjusting nut.
5. Loosen the adjusting nut and remove the outer tie rod nut and the adjusting nut.

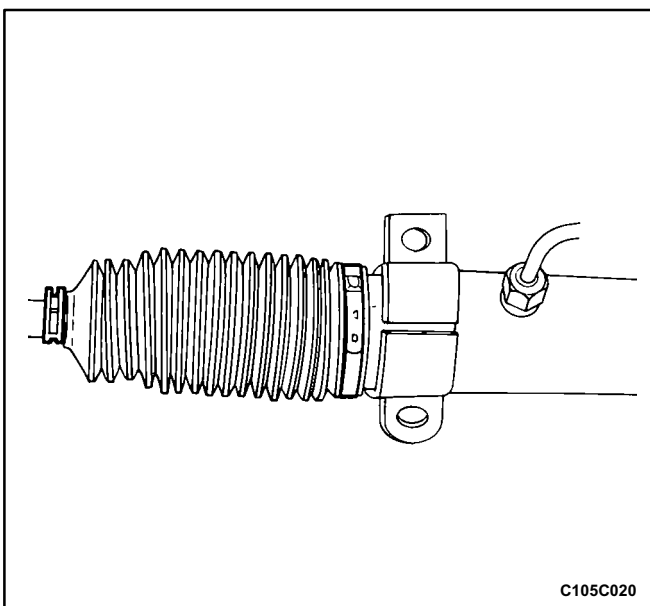
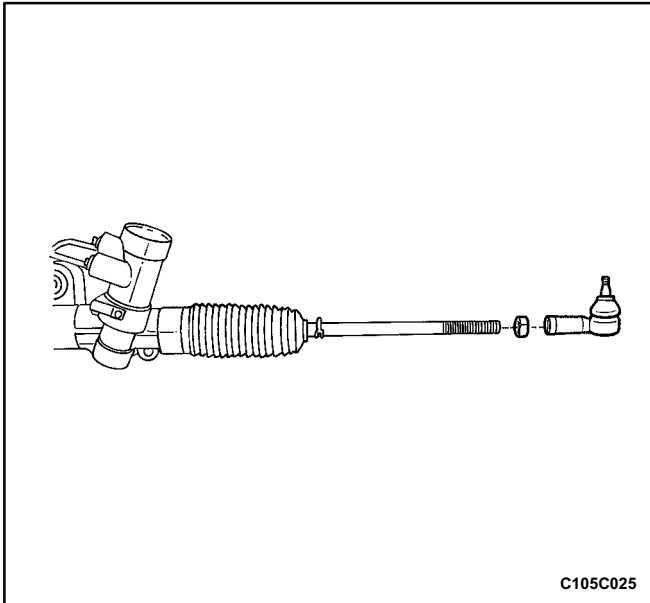

6. Remove the dust boot retaining clamps.

7. Remove the dust boot.

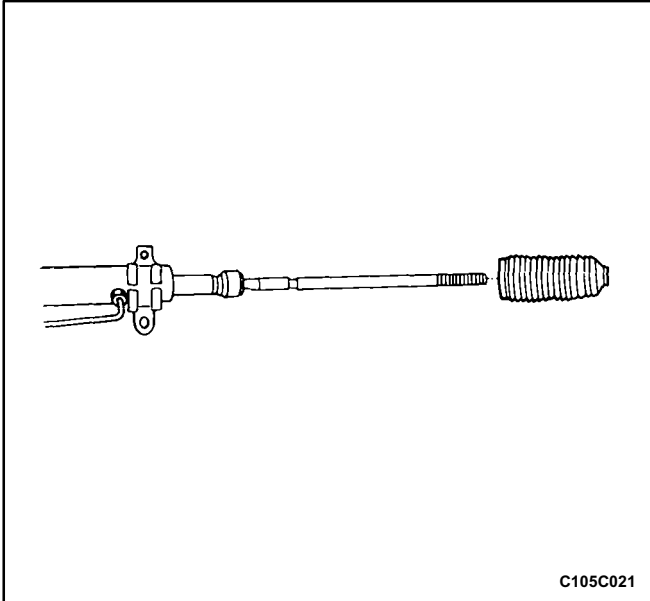

8. Push back the plastic retainer protecting the connection between the inner tie rod and the power steering gear rack.

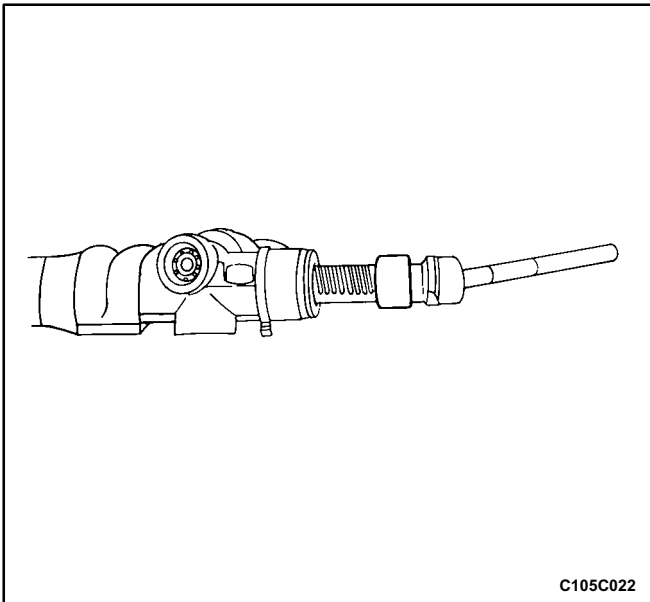

9. Counterhold the pinion side inner tie rod and remove the cylinder side inner tie rod.

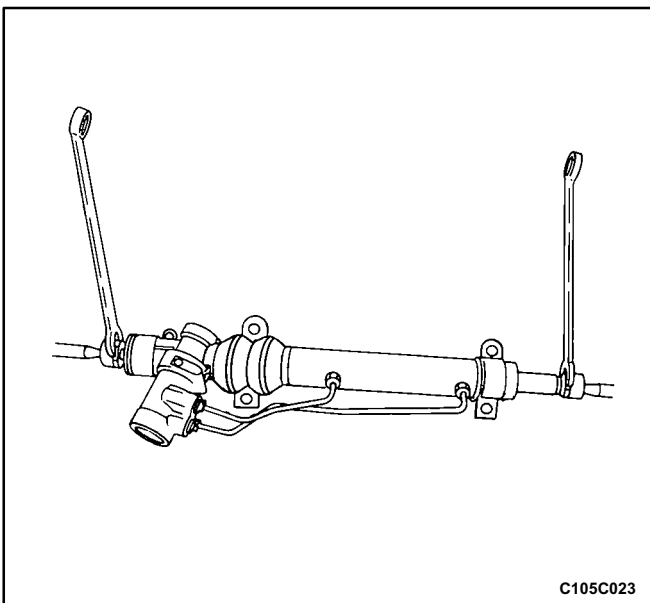

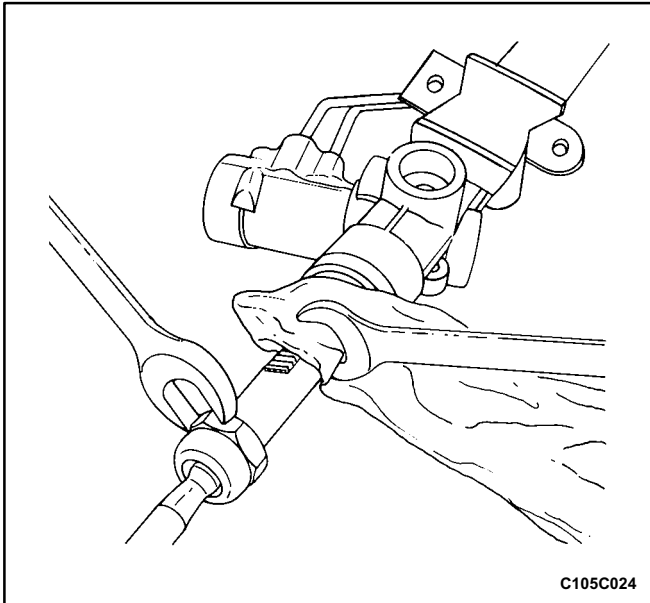

10. Place a rag over the rack, counterhold the rack assembly on the teeth with a wrench, and remove the pinion side inner tie rod.

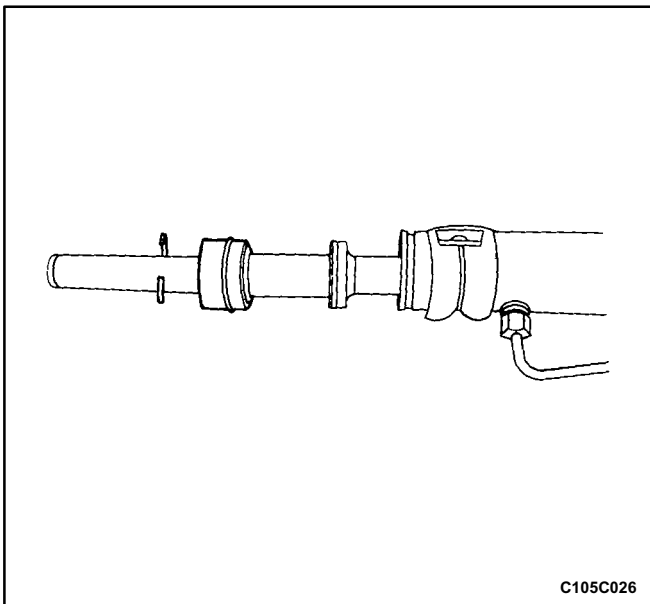

**Important:** The retaining ring can be released by inserting a small screwdriver through the hole in the side of the housing.

11. Remove the bulkhead inner cylinder retaining ring the bulkhead inner cylinder and the rack.

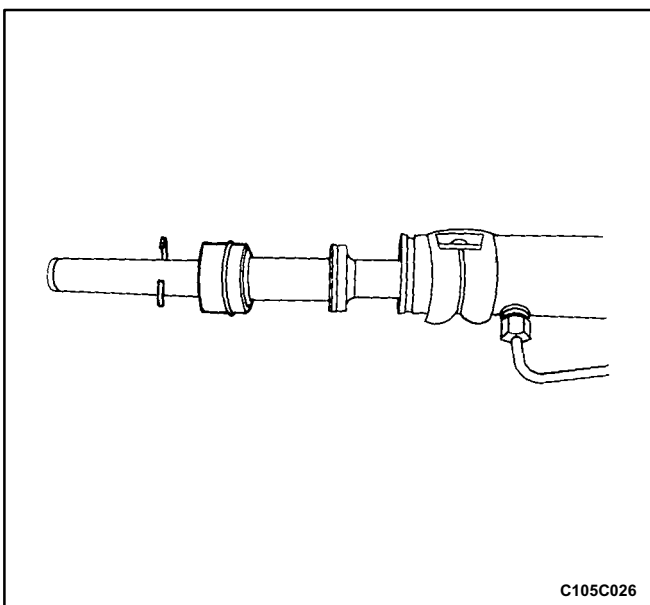

### Assembly Procedure

**Notice:** Coat all the seals with power steering fluid to ensure proper sealing.

1. Install the rack, the bulkhead inner cylinder and the bulkhead inner cylinder retaining ring.

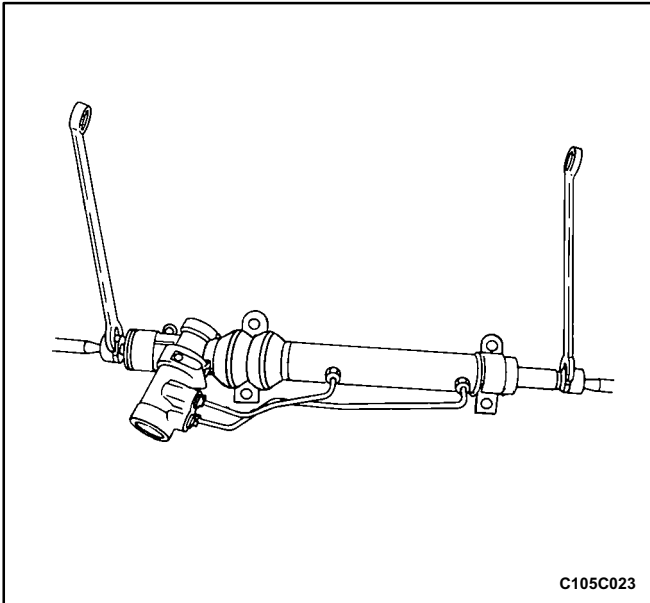

**Notice:** To prevent the inner tie rods from loosening, use Loctite® 242 (or equivalent) on both inner tie rod connections to secure them to the rack shaft.

**Important:** The right and left inner tie rods are unequal in length. Be sure to install the correct inner tie rod on the proper side of the power steering gear.

2. Firmly seat the inner tie rods against the rack and tighten both ends simultaneously.

**Tighten**

Tighten the inner tie rods to 100 N•m (74 lb•ft).

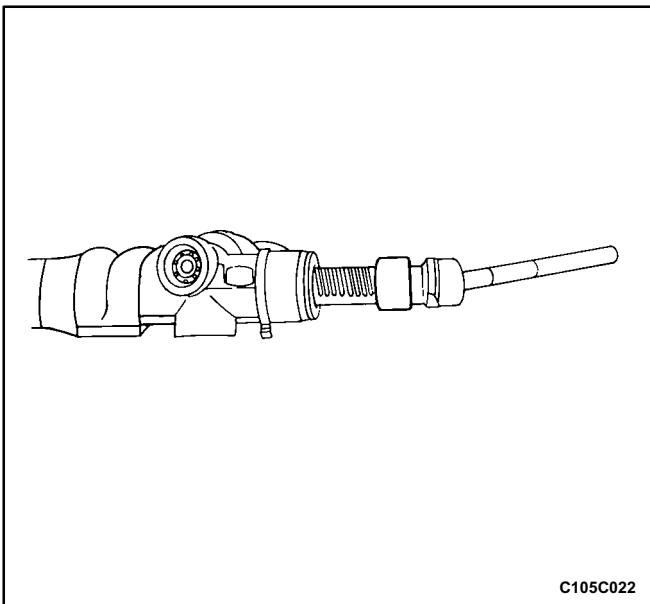

3. Push the plastic retainer back onto the connection between the inner tie rod and the power steering gear rack.

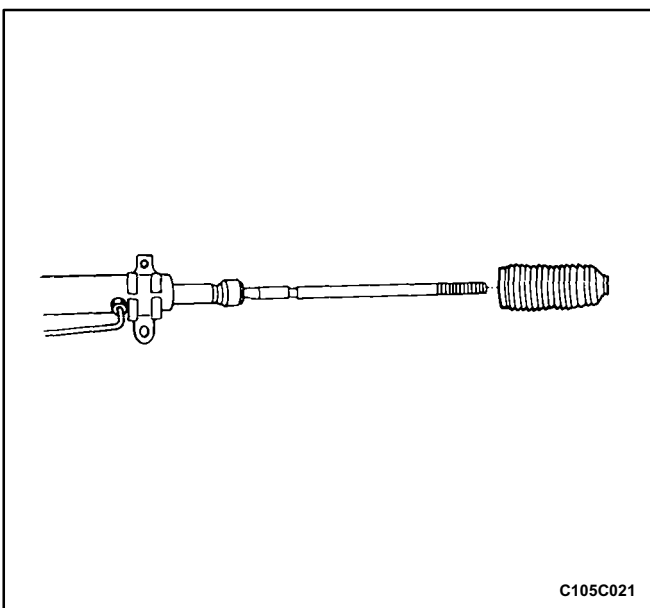

4. Install the dust boot.



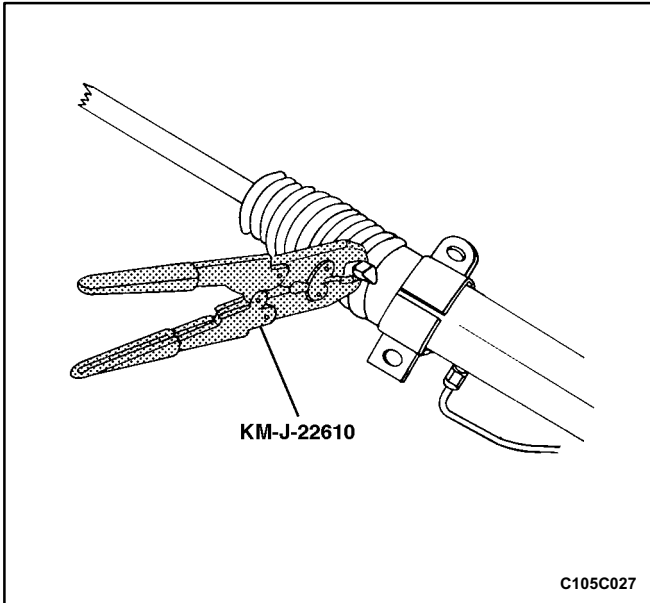

5. Install the cylinder end dust boot retaining clamps with the installer KM-J-22610.

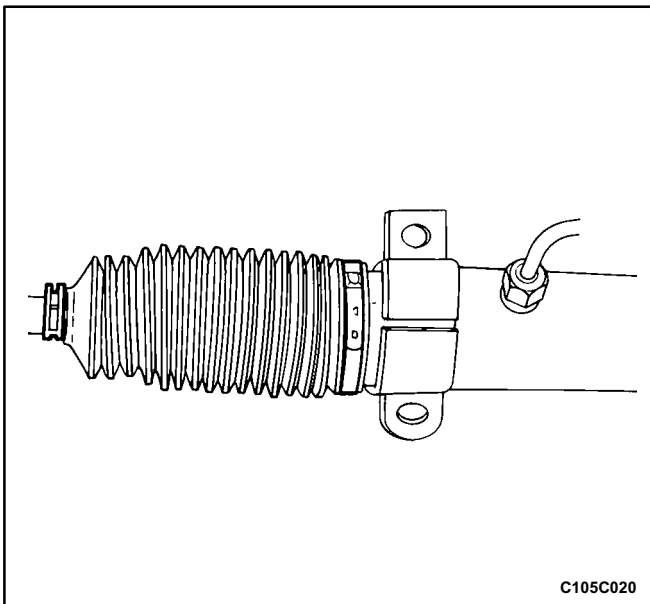

6. Install the tie rod end boot retaining clamps.

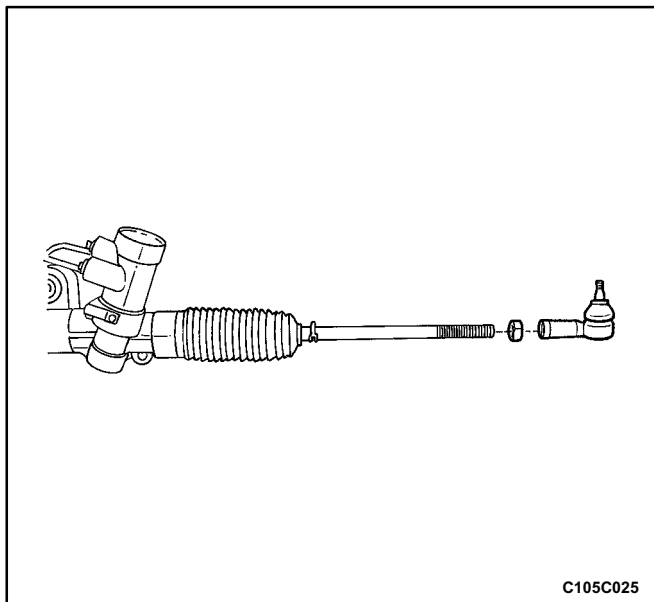

7. Reposition the adjusting nut to the marks on the inner tie rod and install the outer tie rod by twisting it onto the inner tie rod.
8. Perform a front toe adjustment. Refer to *Section 2B, Wheel Alignment*.
9. Tighten the adjusting nut.

### Tighten

Tighten the outer tie rod adjusting nut to 64 N•m (47 lb•ft).

10. Install the rack bearing assembly into the rack and pinion steering assembly. Refer to „Rack Bearing” in this section.
11. Install the valve and pinion assembly into the rack and pinion steering assembly. Refer to „Valve and Pinion” in this section.
12. Install the rack and pinion steering assembly into the vehicle. Refer to „Rack and Pinion Assembly” in this section.

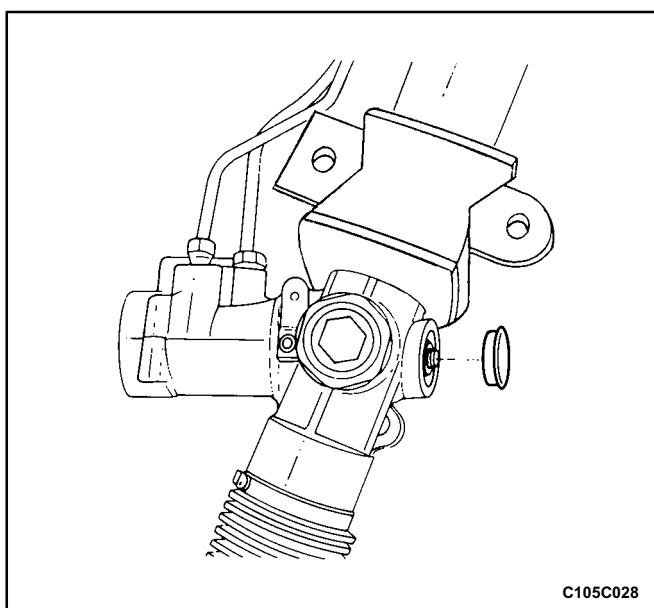

## STUB SHAFT SEALS AND UPPER AND LOWER BEARING

### Disassembly Procedure

1. Remove the rack and pinion steering assembly from the vehicle. Refer to „Rack and Pinion Assembly” in this section.
2. Remove the dust cover from the lower end of the housing.

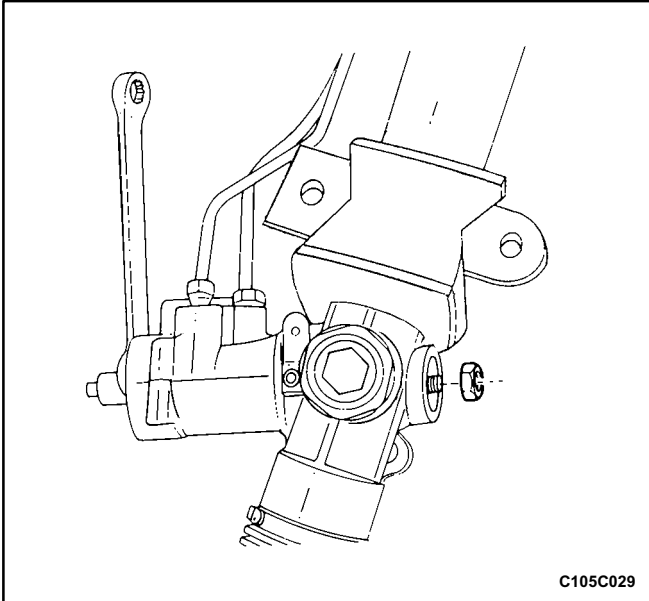

**Notice:** If the stub shaft is not held, damage to the pinion teeth will occur.

3. While holding the stub shaft with a wrench, remove the locknut from the pinion.

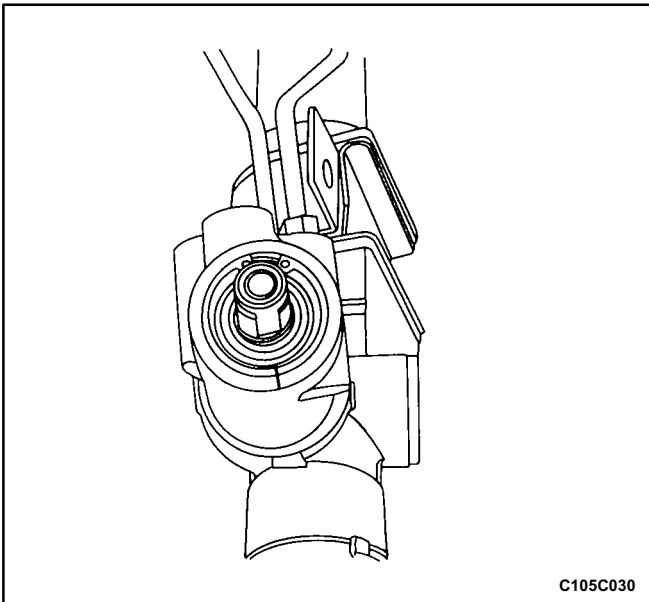

4. With the gear centered, mark the location of the stub shaft notch on the housing to aid in properly installing the valve and pinion assembly.

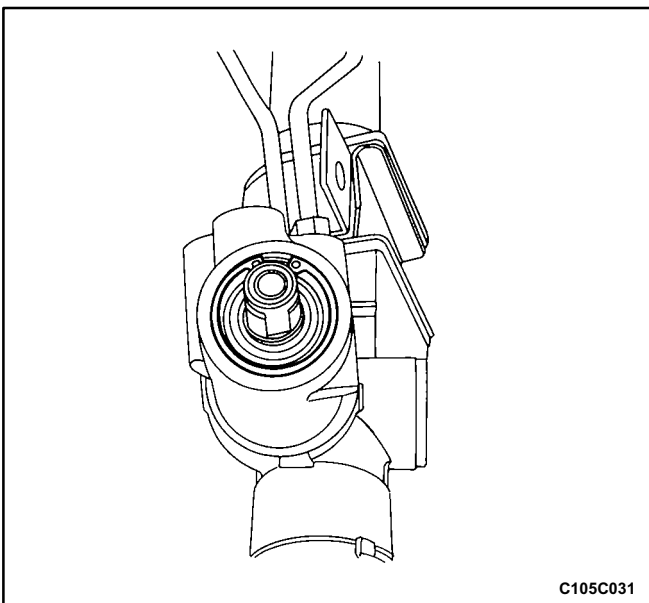

5. Remove the stub shaft retaining ring and, using an arbor press, press on the threaded end of the pinion until it is possible to remove the pinion and valve assembly from the housing.

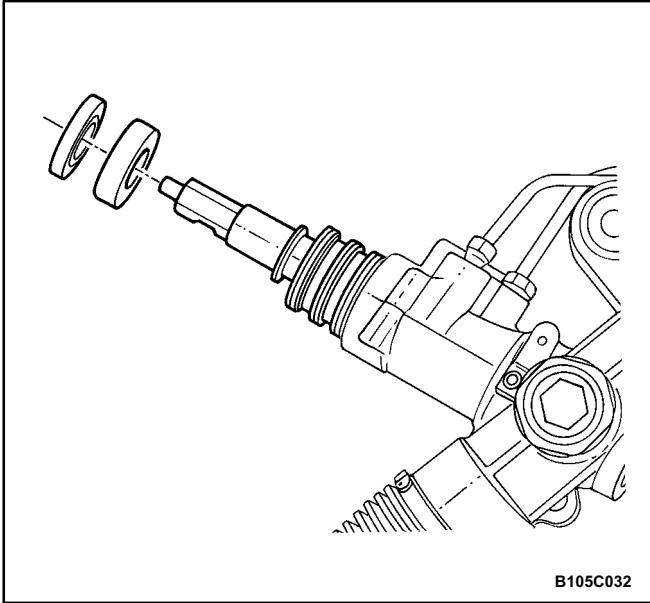

6. Remove the stub shaft dust seal the stub shaft bearing annulus assembly and the valve assembly from the housing. Discard the stub shaft dust seal.

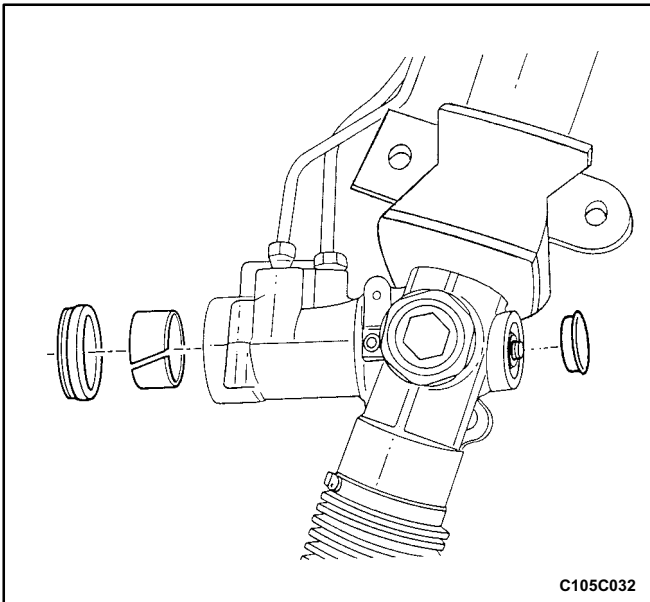

7. Remove the lower valve assembly bearing and the bushing.

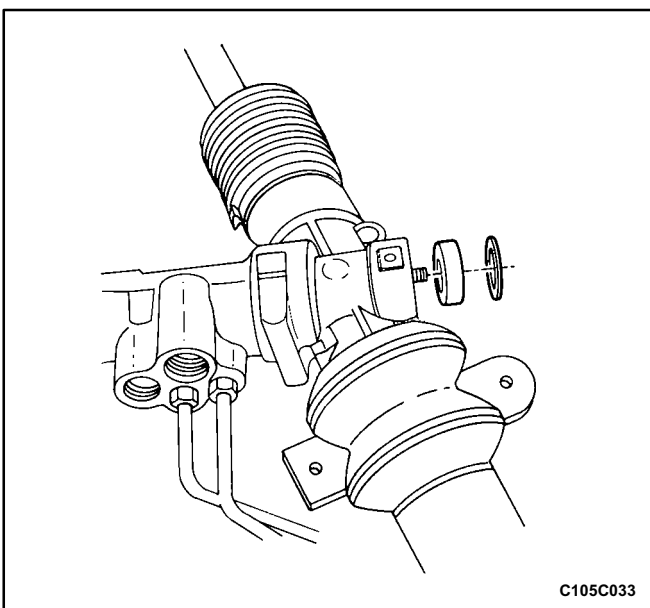

8. Remove the lower bearing assembly retaining ring and press the lower bearing assembly from the lower end of the housing.

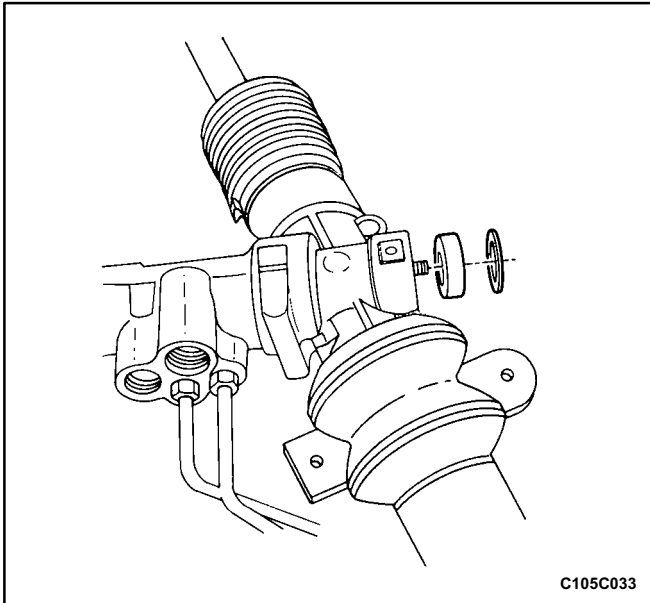

C105C033

### Assembly Procedure

**Notice:** Coat all the seals with power steering fluid to ensure proper sealing.

1. Install the lower bearing assembly and the lower bearing assembly retaining ring into the lower end of the housing.

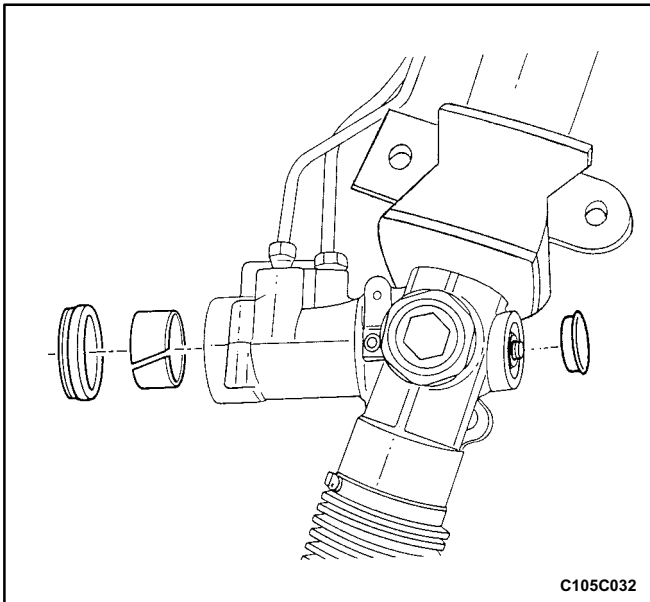

C105C032

2. Install the lower valve assembly bearing and the bushing.

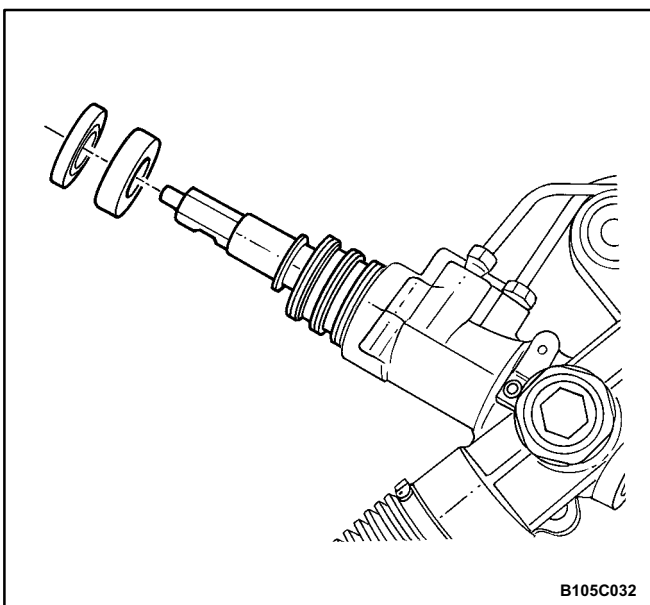

B105C032

3. Center the rack in the housing.
4. Install the the valve assembly, the stub shaft bearing annulus assembly and a new stub shaft dust seal into the housing.

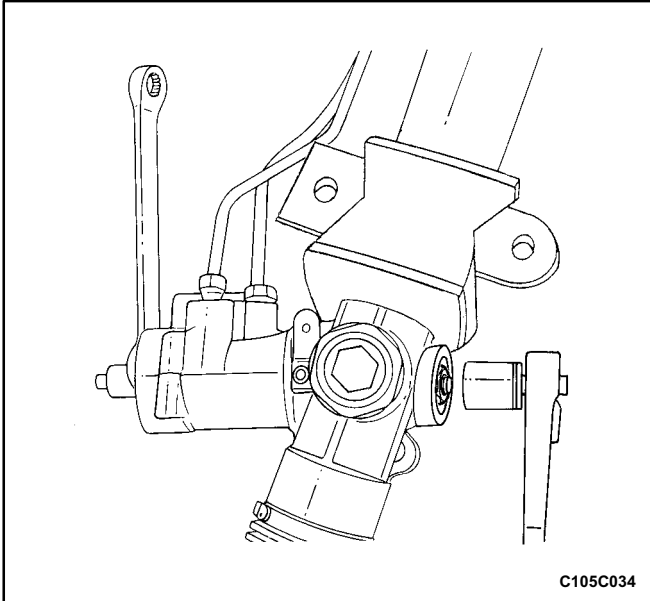

**Important:** When the valve and pinion assembly is fully seated in the housing, be sure that the notch in the stub shaft and the mark on the housing line up.

**Notice:** If the stub shaft is not held, damage to the pinion teeth will occur.

5. While holding the stub shaft, install the locknut onto the pinion shaft.

**Tighten**

Tighten the pinion locknut to 30 N•m (22 lb•ft).

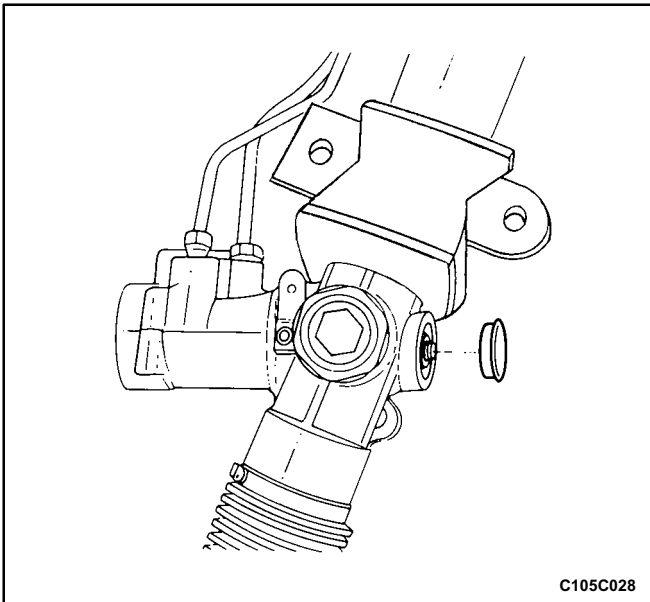

6. Replace the dust cover onto the housing.
7. Install the rack and pinion steering assembly. Refer to „Rack and Pinion Assembly” in this section.

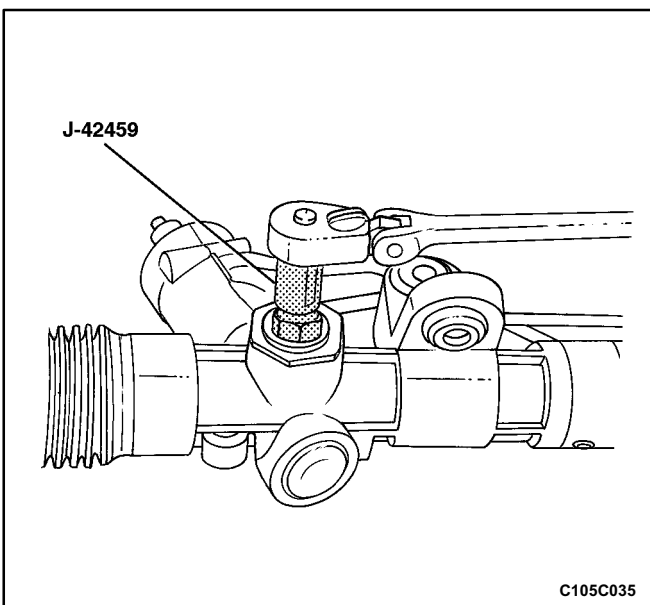

**RACK BEARING**

**Tools Required**

J-42459 Rack Guide Spring Cap Wrench

**Disassembly Procedure**

1. Remove the rack and pinion steering assembly from the vehicle. Refer to „Rack and Pinion Assembly” in this section.
2. Remove the adjuster plug locknut from the adjuster plug, and remove the adjuster plug from the housing with the rack guide spring cap wrench J-42459, or with a 19 mm allen wrench.

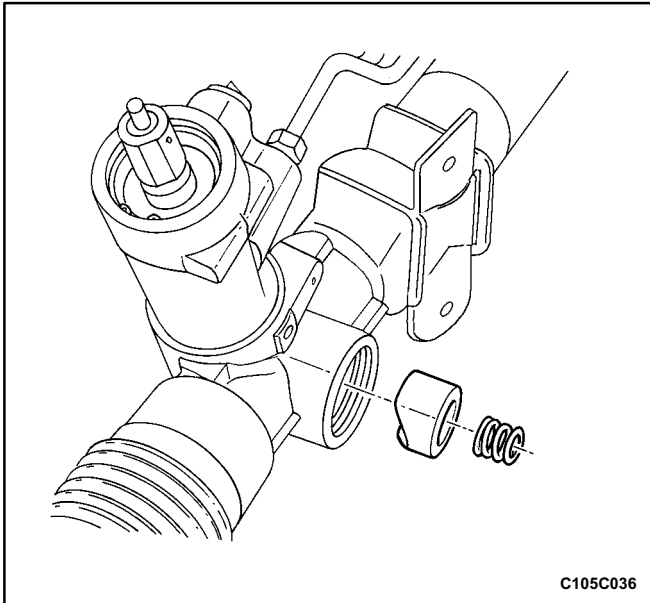

3. Remove the adjuster spring and the rack bearing.

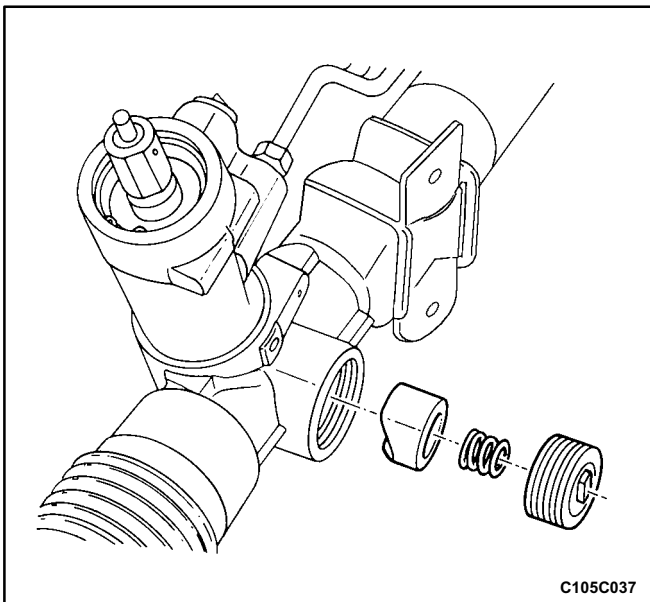

### Assembly Procedure

1. Coat the rack bearing, the adjuster spring and the adjuster plug with lithium based grease and install them into the housing.

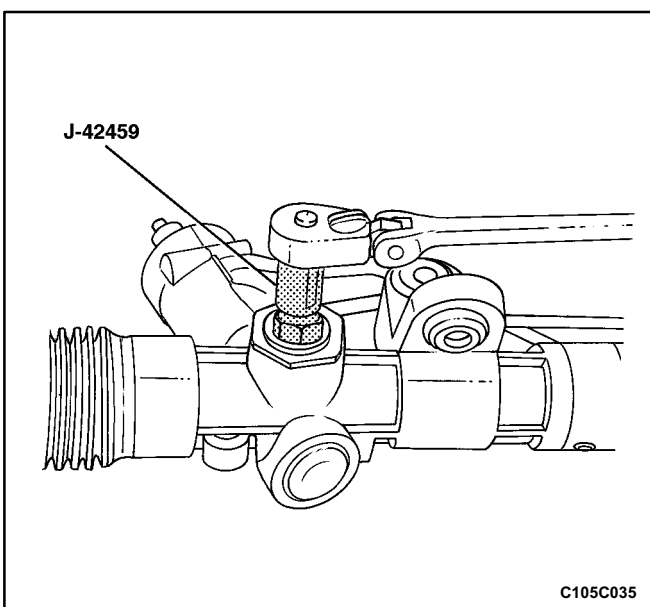

2. With the rack centered, turn the adjuster plug clockwise until a torque of  $7 \text{ N}\cdot\text{m}$  ( $62 \text{ lb}\cdot\text{in}$ ) is obtained, then back it off by 30 to 40 degrees. Check the pinion torque. Maximum pinion preloaded torque is  $1 \text{ N}\cdot\text{m}$  ( $9 \text{ lb}\cdot\text{in}$ ).

3. Thread the locknut on the adjuster plug and tighten it.

### Tighten

Tighten the adjuster plug locknut to  $75 \text{ N}\cdot\text{m}$  ( $56 \text{ lb}\cdot\text{ft}$ ) while holding the adjuster plug stationary with the rack guide spring cap wrench J-42459 or with a 19 mm allen wrench.

4. Install the rack and pinion assembly. Refer to „Rack and Pinion Assembly” in this section.

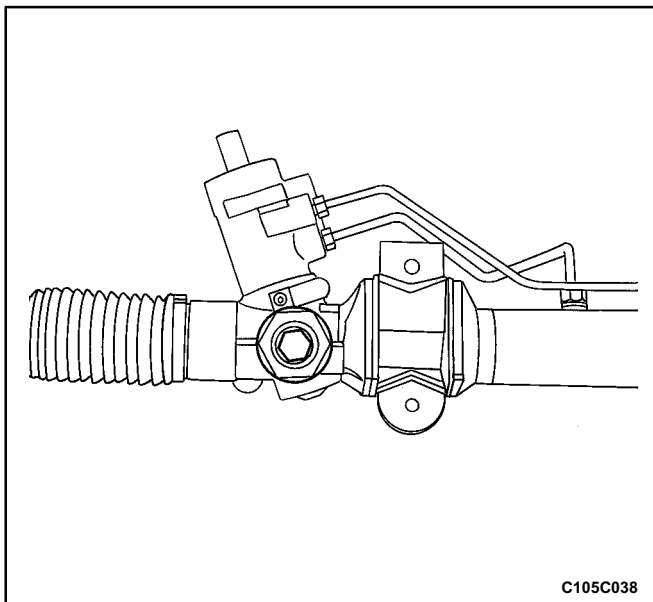

## RACK BEARING PRELOAD ADJUSTMENT

### Adjustment Procedure

1. Raise and suitably support the vehicle.
2. Center the steering wheel.
3. Remove the power steering gear. Refer to „Rack and Pinion Assembly” in this section.
4. Loosen the locknut and turn the adjuster plug clockwise until a torque of 7 N•m (62 lb•in) is obtained, then loosen it by 30 to 40 degrees. Check the pinion torque. Maximum pinion preloaded torque is 1 N•m (9 lb•in).
5. Tighten the locknut on the adjuster plug while holding the adjuster plug stationary.
6. Install the power steering gear. Refer to „Rack and Pinion Assembly” in this section.
7. Be sure to check the returnability of the steering wheel to center position after adjustment.

### Tighten

Tighten the adjuster plug locknut to 75 N•m (56 lb•ft).

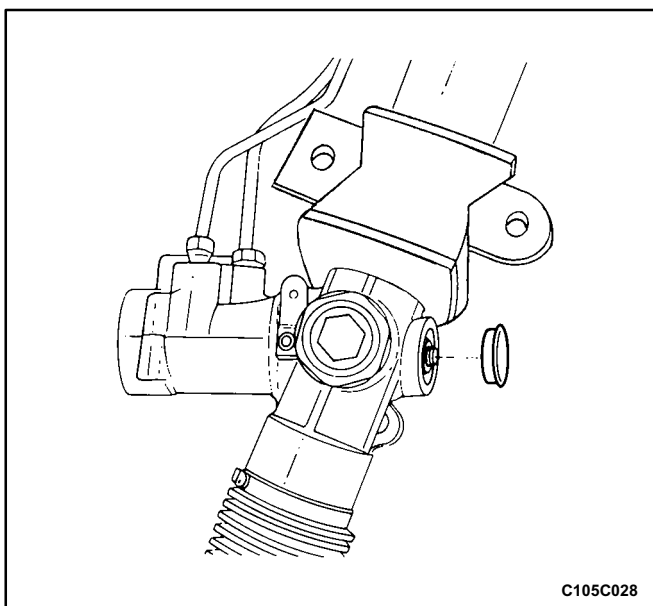

## VALVE AND PINION

### Disassembly Procedure

1. Remove the rack and pinion steering assembly from the vehicle. Refer to „Rack and Pinion Assembly” in this section.
2. Remove the dust cover from the lower end of the housing.



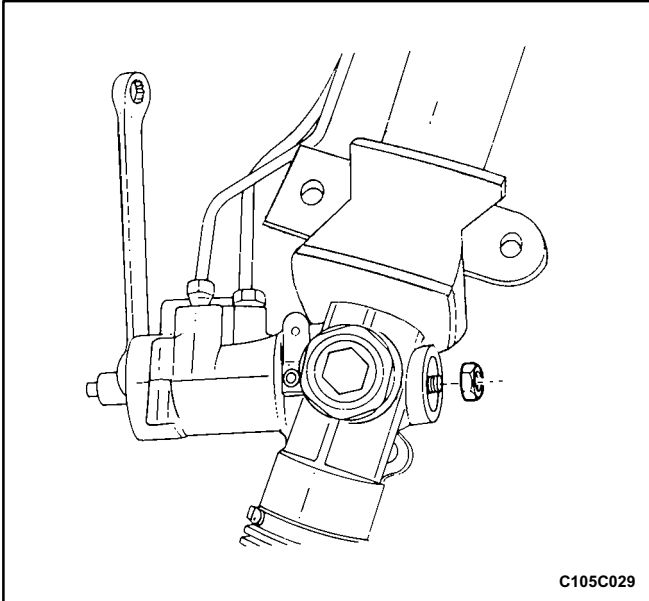

**Notice:** If the stub shaft is not held, damage to the pinion teeth will occur.

3. While holding the stub shaft, remove the locknut from the pinion.

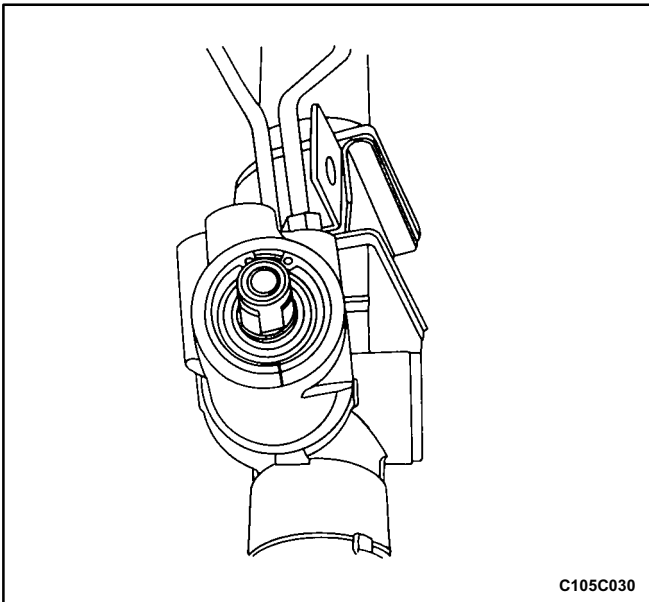

4. With the gear centered, mark the location of the stub shaft notch on the housing to aid in properly installing the pinion and valve assembly.

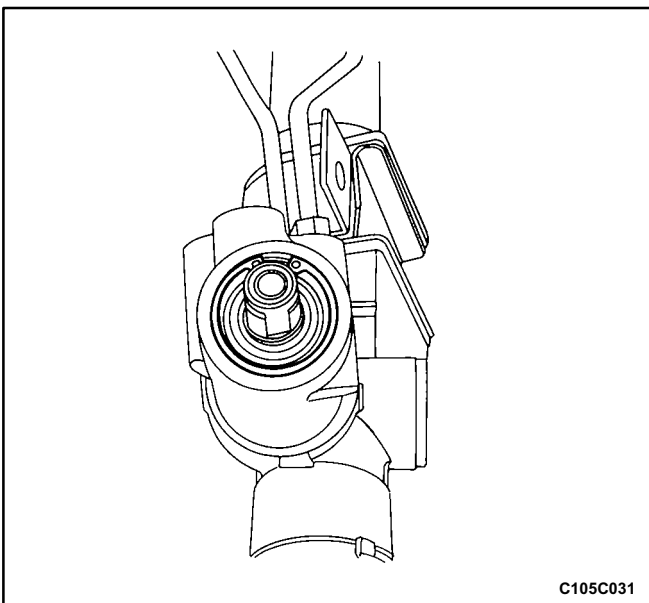

5. Remove the upper housing retaining ring and, using an arbor press, press on the threaded end of the pinion until it is possible to remove the valve and pinion assembly from the housing.

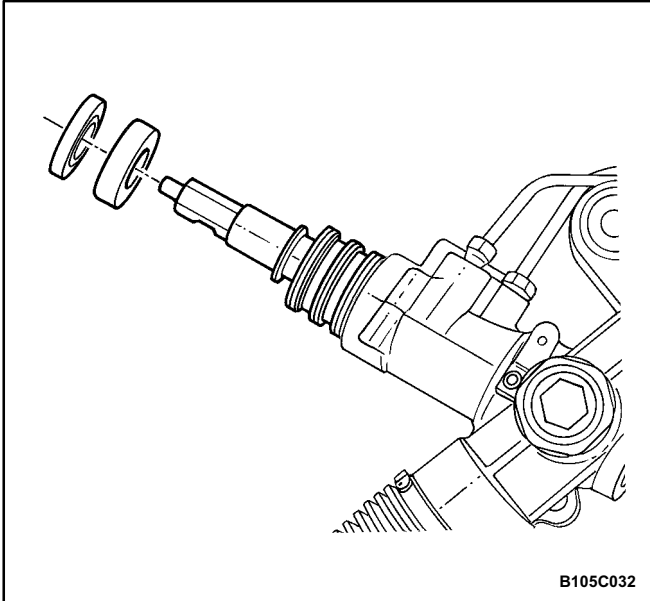

6. Remove the stub shaft dust seal, the stub shaft bearing annulus assembly and the valve and pinion assembly from the housing.

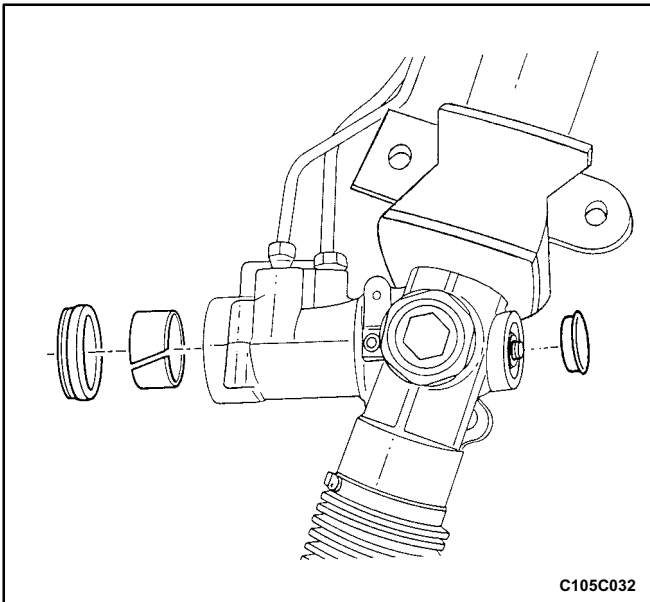

7. Inspect the valve body rings for wear or damage. Replace the valve body rings as needed. Coat the rings with power steering fluid before installation.
8. Remove the lower pinion valve seal and bushing. Discard the seal.

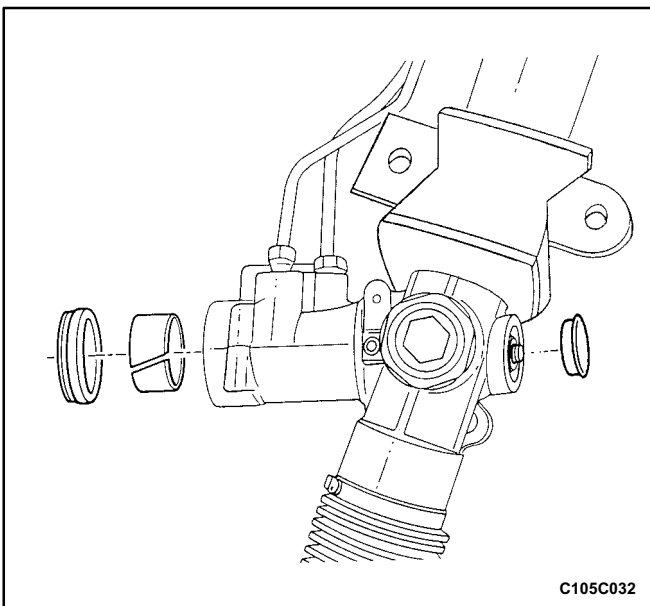

### Assembly Procedure

**Notice:** Coat all of the seals and bushings with power steering fluid to ensure proper sealing.

1. Install the bushing and a new lower pinion valve seal.

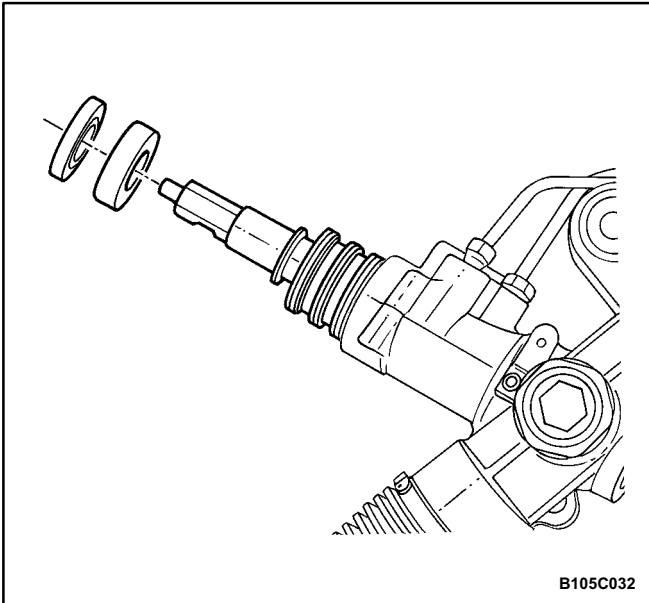

**Important:** When the valve and pinion assembly is fully seated in the housing, be sure the notch in the stub shaft and the mark on the housing line up. If this is not done the vehicle will not pass the straight-ahead check and will have poor steering performance.

2. Install the valve and pinion assembly, the stub shaft bearing annulus assembly and the stub shaft dust seal.

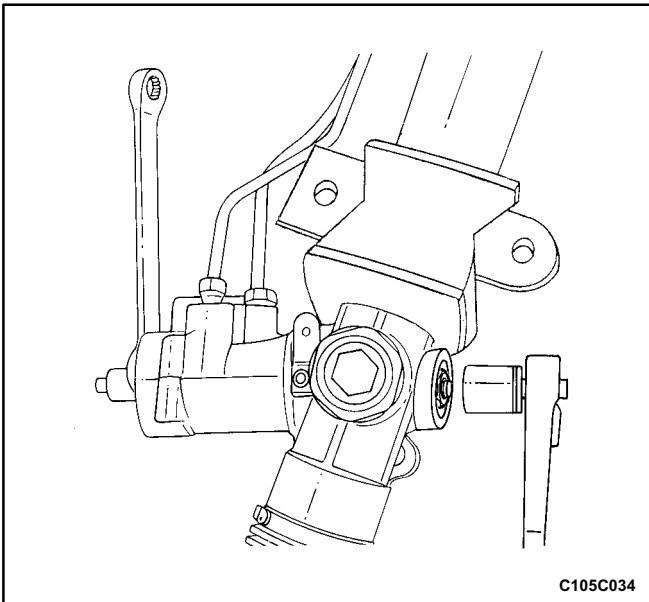

**Notice:** If the stub shaft is not held, damage to the pinion teeth will occur.

3. While holding the stub shaft, tighten the locknut onto the pinion shaft.

### **Tighten**

Tighten the pinion locknut to 30 N•m (22 lb•ft).

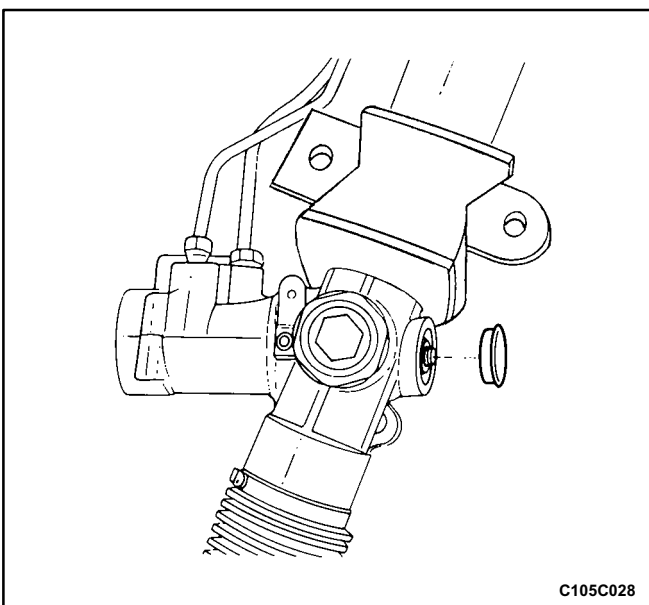

4. Replace the dust cover onto the housing.
5. Install the rack and pinion steering assembly. Refer to „Rack and Pinion Assembly” in this section.
6. Perform the straight ahead check. Refer to „StraightAhead Check” in this section.

# GENERAL DESCRIPTION AND SYSTEM OPERATION

## POWER RACK AND PINION

The power rack and pinion steering system has a rotary control valve that directs hydraulic fluid coming from the hydraulic pump to one side or the other side of the rack piston. The integral rack piston is attached to the rack. The rack piston converts hydraulic pressure to a linear force that moves the rack left or right. That force is then transmitted through the tie rods to the steering knuckles, which turn the wheels.

If power rack and pinion steering is not available, manual rack and pinion control is used; however, with this system, more steering effort is required. The movement of the steering wheel is transferred to the pinion. The rotary movement of the pinion is then transferred through the pinion threads, which mesh with teeth on the rack, thereby causing the rack to move in a linear direction.

A vane type of hydraulic pump provides hydraulic pressure for both steering systems.

## SPEED SENSITIVE POWER STEERING SYSTEM

The speed sensitive power steering (SSPS) system varies the driver effort required to steer as the vehicle speed changes. At low speeds, the system provides maximum power assist for easy turning and parking maneuvers. At higher speeds, the steering power is reduced to provide the driver with firmer steering and directional stability. The SSPS system accomplishes this by reducing the amount of power steering fluid flow from the power steering pump to the power steering gear as the vehicle speed increases. When the vehicle is stationary, the SSPS system provides maximum fluid flow to the steering gear. As the vehicle speed increases, the fluid flow to the steering gear is decreased.

### Control Module

The SSPS control module processes the vehicle speed information from the engine control module (ECM) and uses the steering wheel rotation sensor to provide a control signal to the electronic variable orifice (EVO) actuator located on the power steering pump.

### Electronic Variable Orifice (EVO) Actuator

The electronic variable orifice (EVO) actuator is located on the power steering pump and contains a solenoid operated pintle valve. Fluid leaving the pump passes through an orifice in the actuator tip. When the EVO actuator is powered by the SSPS control module, the pintle moves into the orifice and reduces the power steering fluid flow. As the vehicle speed increases, current from the SSPS control module increases, and the pintle blocks more and more of the orifice.

### Steering Wheel Rotation Sensor

The steering wheel rotation sensor is located at the end of the steering column housing and is used to send a

signal to the controller when abrupt or evasive steering maneuvers are needed.

### Power Steering Pressure Hose

SSPS vehicles have a specific pressure hose assembly which includes an in line check valve in the rack and pinion assembly. This reduces the amount of steering wheel „kick” when driving over irregular road surfaces while operating at speeds with reduced flow rate and pressure.

### Power Rack and Pinion

Except for differences in valve machining, the design of the SSPS power rack and pinion assembly is the same as for the a non SSPS system. The steering wheel movement is transferred to the pinion via the intermediate shaft. The pinion moves the rack left or right through meshing the pinion and the rack teeth. The force is then transmitted through the tie rods and steering knuckle to steer the wheels.

The power rack and pinion steering system has a rotary control valve which directs the hydraulic fluid from the power steering pump to one side or the other side of the rack piston. The piston is attached to the rack and uses hydraulic pressure to move the rack left or right. The rotary control valve regulates the degree of assist by responding to the driver's torque input.

If hydraulic assist is not available, manual control is maintained. However, under this condition, more steering effort is required.

### Power Steering Pump

The standard vane type pump, which provides hydraulic pressure for the system, incorporates a special discharge fitting to hold the EVO actuator.

### System Operation

System operation originates with input from the vehicle speed sensor via the engine control module to the SSPS control module. The SSPS control module sends a signal to the SSPS actuator to vary the rate of fluid flow output by the power steering pump.

### Circuit Operation

The SSPS system uses inputs from the speed sensor and steering wheel rotation sensor to the SSPS controller to determine the desired amount of power steering assist.

The SSPS control module constantly compares the amount of current flowing through the EVO actuator to the desired current it has calculated. The EVO actuator has a pintle that moves in and out of an orifice, regulating power steering fluid flow. The SSPS control module can change the amount of current flowing through the EVO actuator by varying the output duty cycle. If the EVO actuator is disconnected, the pintle will be pulled out of the orifice for maximum power steering assist.

The SSPS control module has the ability to detect faults in the steering wheel rotation sensor, the EVO actuator, or the circuitry to those components. Any default detected will cause the power steering assist to remain

at maximum with the pintle in its normally retracted position for all speeds.

When the system is operating normally, increasing the vehicle speed will decrease power steering assist, allowing the driver to have improved road feel and directional stability. When sudden steering wheel turns are made, as in evasive maneuvers, they are detected by the SSPS control module through the steering wheel rotation sensor. When detected, the SSPS control

module reduces current to the EVO actuator, allowing greater power steering assist.